



KERN & Sohn GmbH

Ziegelei 1
D-72336 Balingen
email: info@kern-sohn.com

Phone: +49-[0]7433- 9933-0
Fax: +49-[0]7433-9933-149
Internet: www.kern-sohn.com

Operating Manual Pallet truck scales

KERN VHT

Version 1.0
01/2009
GB



VHT-BA-e-0910



KERN VHT

Version 1.0 01/2009

Operating instructions Pallet truck scale

Table of Contents

1	TECHNICAL DATA	4
2	DECLARATION OF CONFORMITY	5
3	BASIC INSTRUCTIONS FOR SCALES	6
3.1	Proper use.....	6
3.2	Improper Use	6
3.3	Warranty	6
3.4	Monitoring of Test Resources.....	7
4	BASIC SAFETY INSTRUCTIONS FOR SCALES	7
4.1	Pay attention to the instructions in the Operation Manual	7
4.2	Personnel training	7
5	TRANSPORTATION & STORAGE	7
5.1	Testing upon acceptance	7
5.2	Packaging.....	7
6	UNPACKING, SETUP AND COMMISSIONING	8
6.1	Site of installation, place of operation for scales	8
6.2	Scope of delivery	9
6.3	Battery power supply	9
6.4	Commissioning.....	10
6.5	Overview of display	10
6.6	Keyboard overview.....	12
7	FUNCTIONS OF DISPLAY UNIT	13
7.1	Multiple range display.....	13
7.2	Prior to weighing: ZERO-POINT CHECK.....	13

7.3	Gross weighing	13
7.4	Net weighing: TARING BY PRESSING A BUTTON	13
7.5	Net weighing: MANUAL TARE INPUT	14
7.6	Input of the code number	15
7.7	Parts counting	16
7.7.1	Piece counting by placing the parts	16
7.7.2	Piece counting by means of input piece weight.....	17
7.8	Adding	18
7.9	Weighing units switch-over.....	18
7.10	PRINTING	19
7.11	PAPER CHANGE.....	21
7.12	Change of date and time on the printout.....	23
7.13	Set limit value	23
8	SERVICE, MAINTENANCE, DISPOSAL	24
8.1	Cleaning	24
8.2	Service, maintenance.....	24
8.3	Disposal.....	24
9	ERROR MESSAGES	25
10	INSTANT HELP.....	26

1 Technical Data

KERN	VHT 2T0.2T
Readability (d)	200 g; 500 g; 1000 g
Weighing range (max)	200 kg; 500 kg; 2000 kg;
Reproducibility	200 g; 500 g; 1000 g
Linearity	200 g; 500 g; 1000 g
Warm-up time	10 min
Allowable ambient temperature	-10° C + 40° C
Humidity of air	max. 95 %
Weighing Units	kg
Rechargeable battery	12 V
Loading time of battery	6 h
Auto Off	3 min
Net weight	125 kg

Dimensions:

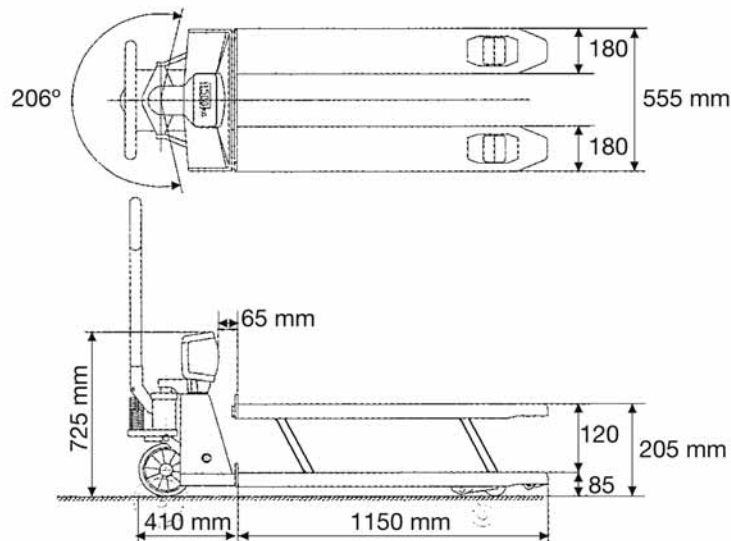

2 Declaration of conformity



KERN & Sohn GmbH

D-72322 Balingen-Frommern

Postbox 4052

email: info@kern-sohn.de

Phone: 0049-[0]7433- 9933-0

Fax: 0049-[0]7433-9933-149

Internet: www.kern-sohn.de

Declaration of conformity

EC-Konformitätserklärung
EC- Déclaration de conformité
EC-Dichiarazione di conformità
EC- Declaração de conformidade
EC-Deklaracja zgodności

EC-Declaration of -Conformity
EC-Declaración de Conformidad
EC-Conformiteitverklaring
EC- Prohlášení o shode
ЕС-Заявление о соответствии

D	Konformitäts- erklärung	Wir erklären hiermit, dass das Produkt, auf das sich diese Erklärung bezieht, mit den nachstehenden Normen übereinstimmt.
GB	Declaration of conformity	We hereby declare that the product to which this declaration refers conforms to the following standards.
CZ	Prohlášení o shode	Tímto prohlašujeme, že výrobek, kterého se toto prohlášení týká, je v souladu s níže uvedenými normami.
E	Declaración de conformidad	Manifetamos en la presente que el producto al que se refiere esta declaración está de acuerdo con las normas siguientes
F	Déclaration de conformité	Nous déclarons avec cela responsabilité que le produit, auquel se rapporte la présente déclaration, est conforme aux normes citées ci-après.
I	Dichiarazione di conformità	Dichiariamo con ciò che il prodotto al quale la presente dichiarazione si riferisce è conforme alle norme di seguito citate.
NL	Conformiteit- verklaring	Wij verklaren hiermede dat het product, waarop deze verklaring betrekking heeft, met de hierna vermelde normen overeenstemt.
P	Declaração de conformidade	Declaramos por meio da presente que o produto no qual se refere esta declaração, corresponde às normas seguintes.
PL	Deklaracja zgodności	Niniejszym oświadczamy, że produkt, którego niniejsze oświadczenie dotyczy, jest zgodny z poniższymi normami.
RUS	Заявление о соответствии	Мы заявляем, что продукт, к которому относится данная декларация, соответствует перечисленным ниже нормам.

Electronic Scale: **KERN VHB, VHE, VHS, VHT**

Mark applied	EU Directive	Standards
CE	2004/108/EC	EN 55022 :1994 /A1 : 1995/A2 : 1997 Class A EN 50082-1 : 1992 EN 61000-3-2 : 1995/A1: 1998 / A2:1998 EN 61000-3-3 : 1995
	2006/95/EC	EN 60950 : 1992/A1: 1993 / A3: 1995 / A4: 1997 / A11: 1997

Date: 24.09.2008

Signature:

Gottl. KERN & Sohn GmbH
Management

Gottl. KERN & Sohn GmbH, Ziegelei 1, D-72336 Balingen, Tel. +49-[0]7433/9933-0, Fax +49-[0]7433/9933-149

3 Basic instructions for scales

3.1 Proper use

The balance you purchased is intended to determine the weighing value of material to be weighed. It is intended to be used as a “non-automatic” balance, i.e. the material to be weighed is manually put on the weighing plate. The center of gravity of the load should be in the middle of the plate. As soon as a stable weighing value is reached the weighing value can be read.

3.2 Improper Use

Do not use balance for dynamic weighing. In the event that small quantities are removed or added to the material to be weighed, incorrect weighing results can be displayed due to the “stability compensation” in the balance. (Example: Slowly draining fluids from a container on the balance.)

Do not leave permanent load on the balance. This may damage the measuring system.

Impacts and overloading exceeding the stated maximum load (max) of the balance, minus a possibly existing tare load, must be strictly avoided. Balance may be damaged by this.

Never operate balance in explosive environment. The serial version is not explosion protected.

The structure of the balance may not be modified. This may lead to incorrect weighing results, safety-related faults and destruction of the balance.

The balance may only be used according to the described conditions. Other areas of use must be released by KERN in writing.

3.3 Warranty

Warranty claims shall be voided in case

- Our conditions in the operation manual are ignored
- The appliance is used outside the described uses
- The appliance is modified or opened
- Mechanical damage and damage caused by media, liquids
- Natural wear and tear
- The appliance is improperly set up or incorrectly electrically connected
- The measuring system is overloaded

3.4 Monitoring of Test Resources

In the framework of quality assurance the measuring-related properties of the balance and, if applicable, the testing weight, must be checked regularly. The responsible user must define a suitable interval as well as type and scope of this test. Information is available on KERN's home page (www.kern-sohn.com) with regard to the monitoring of balance test substances and the test weights required for this. In KERN's accredited DKD calibration laboratory test weights and balances may be calibrated (return to the national standard) fast and at moderate cost.

4 Basic safety instructions for scales

4.1 Pay attention to the instructions in the Operation Manual

Carefully read this operation manual before setup and commissioning, even if you are already familiar with KERN balances.

4.2 Personnel training

The appliance may only be operated and maintained by trained personnel.

5 Transportation & Storage

5.1 Testing upon acceptance

When receiving the appliance, please check packaging immediately, and the appliance itself when unpacking for possible visible damage.

5.2 Packaging

Keep all parts of the original packaging in case you need to return the appliance. Only use original packaging for returning.

Before sending, disconnect all connected cables and loose/movable parts.

6 Unpacking, Setup and Commissioning

6.1 Site of installation, place of operation for scales

The balances are designed in a way that reliable weighing results are achieved in common conditions of use.

You will work accurately and fast, if you select the right location for your balance.

Therefore, observe the following for the installation site:

- The load must be lifted clear of the display unit's case and other pallets.

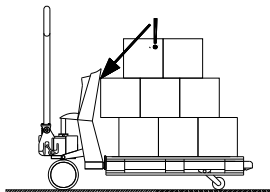

Incorrect lifting of a load

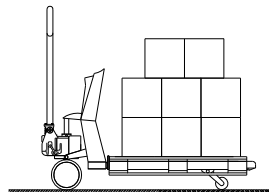

Correct lifting of a load

- The accuracy of the weighing system is falling by approximately 0.1 % per degree if there is a slant of more than 2°. Holes and unevenness, too, have this effect. A smooth floor is ideal.
- Optimum accuracy in weighing results is achieved if the load centre is between the forks. The forks are easily bent and twisted when the load is off-centre. This may result in diminished accuracy.
In verifiable models off-centre loads, or slants affecting accuracy, activate the inclination switch which in turn disconnects the display.

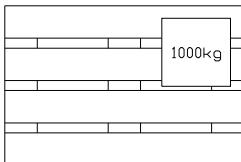

Non-optimal positioning of load

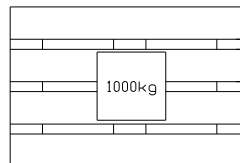

Optimal positioning of load

- Temperature range: The maximum deviation for 0.1% of the weighed load is between -10 and +40°C. Outside this temperature range deviations of up to 0.3% may occur.
- Avoid jarring during weighing
- Protect the balance against high humidity, vapours and dust
- Do not expose the device to extreme dampness for longer periods of time. Non-permitted condensation (condensation of air humidity on the appliance) may occur if a cold appliance is taken to a considerably warmer environment. In this case, acclimatize the disconnected appliance for ca. 2 hours at room temperature.

- Major display deviations (incorrect weighing results) may be experienced should electromagnetic fields (e.g. due to mobile phones or radio equipment), static electricity accumulations or instable power supply occur. Change location or remove source of interference.

6.2 Scope of delivery

Serial accessories:

- Pallet truck scales
- Operating Manual
- Paper rolls
- Rechargeable battery with power supply unit

6.3 Battery power supply



The voltage supply takes place via an interchangeable battery module. With a full-loaded battery module you can weigh approx. 35 hours without interruption (system without printer).

If the loading status of the rechargeable battery is too low, the display shows: “**LO-BA**”. If the battery is completely exhausted, the lifting truck switches off automatically.

It is recommended to load the battery at least 6 hours. In that manner a loss of battery capacity is avoided.

If the system is used in shift work or if the system has an integrated printer, it is recommended to purchase a supplementary battery module.

The battery module is loaded using the delivered loading device. When loading, the LED of the loading device is lighting. If that LED is off, the battery has been reloaded. An overloading of the rechargeable battery is not possible as the loading device switches off automatically.

6.4 Commissioning

To activate the weighing system, press the  button.



The operating temperature for the electronic system and the weighing cells will have been reached after three to five minutes. . Prior to this, deviations of c. 0.3% are possible.

Loads should not be lifted before this zero adjust is complete.

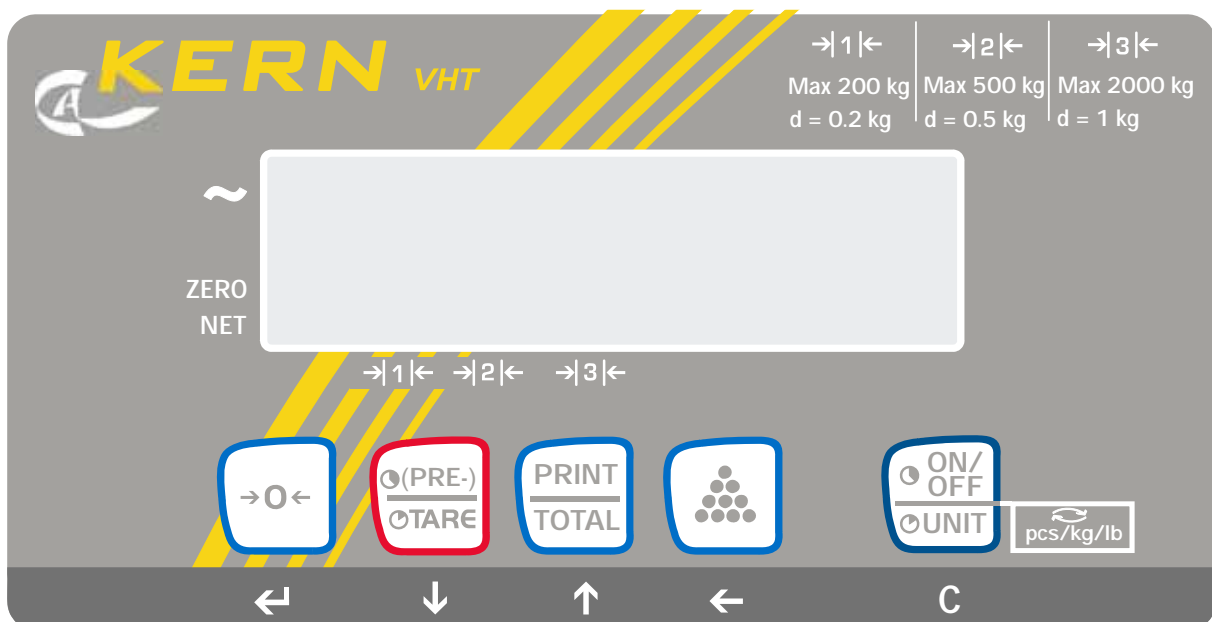
6.5 Overview of display



The seven displays provide the following information:

-  ◀ The weighing system (incl. load) is stable
-  The indicated weight has a negative value
- ZERO** ◀ the indicated weight is within the zero range
- NET** ◀ the indicated value is the net weight
- 1 ←** ▼ the indicated value is within the weighing range 1
- 2 ←** ▼ the indicated value is within the weighing range 2
- 3 ←** ▼ the indicated value is within the weighing range 3

DISPLAY- MESSAGES

The following messages may appear on the display:

Err 0 I	Error message
AddEd	Confirmation addition
Add 10	Add piece quantity
Adj 08	Display of adjustment value
TareE	Taring carried out, dosing process
donE	Confirmation dosing carried out
PR 00	Display of parameter number
Stop	Dosing process cancelled
hr 00	Display of hours setting
mn 00	Display of minutes setting
da 00	Display of day setting
mo 00	Display of month setting
ye 00	Display of year setting

6.6 Keyboard overview

Each button provides two operating as well as one input function.

Key	Operation function 1 (press shortly)	Operation function 2 (press longtime)	Input function
	Zero point correction	Input code	Enter
	Taring	Input tare weight	Entering numeric values: Decreases the numeric value of flashing digit by 1.
	Print out the weight value and add it to the total weight	Check the subtotal and print out the end total	Entering numeric values: Increases the numeric value of flashing digit by 1.
	Calculation of the piece weight	Input of the piece weight	Entering numeric values: Confirms the flashing value.
	Unit commutation	On / Off	Correction



The actuation of a key will only be accepted if the load is stable and the message “load stable” is lit up. The display unit only carries out functions as long as the load is stable.



CAUTION

If the weighed weight exceeds the set maximum, the display will show: “ERRO2”. To prevent damage to the display unit or the weighing cells, please lighten the load of the weighing system instantly.

7 Functions of display unit

7.1 Multiple range display

The size of the display steps depends on the measured weight:

- from 0 to 200 kg the weight is displayed in 0.2 kg;
- from 200 to 500 kg the weight is displayed in 0.5 kg;
- from 500 to 2200 kg the weight is displayed in 1 kg.

Because of this weight-dependant size of the display step it is possible to weigh smaller weights with more exactness. The display step does not change during weighing. If e.g. a weight of 650 kg is weighed, the display step will not change to 0.5 kg, if the weighed quantity reaches 500 kg. The weight will continue to be displayed in 1 kg-steps.

7.2 Prior to weighing: ZERO-POINT CHECK

Prior to each weighing process ensure that the system is unloaded and clear of obstructions. The display unit provides automatic zero adjustment. This means, that small deviations from the zero-point are corrected automatically. If the display unit does not correct the zero-point automatically you will have to carry out a manual

correction with the help of the  key.

7.3 Gross weighing

After the load was lifted, the display shows the gross value of the weighed weight.

7.4 Net weighing: TARING BY PRESSING A BUTTON

The display unit offers an option that allows tare weights to be reset to zero by pressing a button. In this way net weight changes can be traced. After taring, the display unit will once again start at the smallest display step.

⇒ Lift the load.

⇒ Press button .

- The display unit shows zero.
- The lit up display "NET", indicates that a tare weight is active.



⇒ Loading and unloading the net load.

- The net value for the weighed weight is shown on the display.
- For unloading this will be a negative value.









⇒ By actuating the  button the gross weight can be read.

7.5 Net weighing: MANUAL TARE INPUT

You may enter the tare weight at any time, that is, regardless whether the scales are in a loaded or unloaded state. To achieve higher accuracy, a tare weight with a higher resolution may be entered, regardless of the size of the weight and the display steps of the indicator.

- ⇒ Press  button for approx. 3 seconds.
 - The most recently used tare value appears.
 - □ The segment on the right is flashing.
- ⇒ Press  [] button, if the displayed tare value will be used once more.

or:



- ⇒ Press  button for approx. 3 seconds.
- ⇒ Press the numeric up  [] or down  [] button until the flashing number has reached the desired value.
- ⇒ To move to the next segment, press the button  [].
- ⇒ Repeat this action until the display shows the desired tare value.
- ⇒ To activate the tare weight (*but not for storing*): Press the  [] button for three seconds, to confirm the value.
- ⇒ The tare weight is now activated.
- ⇒ “NET” appears.
 - ⇒ If the system is loaded at this moment, the net value of the weighed weight appears on the display.
 - ⇒ If the system is unloaded, the system indicates the entered tare value negative.
- ⇒ The entered value remains active until the weighing system is switched off or if a zero setting is made.

7.6 Input of the code number

The display device offers the possibility to enter a code number of max. 5 positions. Input of a code is a topic if the weighing system is equipped with a printer or other additional devices in order to identify the different weighings at a later processing of the data.



⇒ Press  button for approx. 3 seconds

On the display device appears the code entered as last. The right-hand cipher flashes.

⇒ Press anew the   button, when the displayed code shall be maintained. The code is activated and the balance returns into the weighing mode.

or:

⇒ Press button   or   in order to change the code. On the display device appears a new code.

⇒ Press   button in order to accept the new code. The code is activated and the balance returns into the weighing mode.

⇒

7.7 Parts counting

During piece counting parts can either be counted into a container or out of a container. To count a greater number of parts the average weight per part has to be determined with a small quantity (reference quantity).

The larger the reference quantity, the higher the counting exactness. High reference must be selected for small parts or parts with considerably different sizes.



CAUTION

The larger the reference quantity, the more accurate the parts counting.

ATTENTION! If the exactness during calculation is too low, the indicator will show "ERR05". Press any button to return to the piece counting mode, and increase the quantity to be calculated.

7.7.1 Piece counting by placing the parts

⇒ Press the  button.



In the display appears e.g. „add10“. The 'kg' display vanishes and the 'pcs' display appears.

⇒ Put 10 sample parts onto the balance

⇒ Press  button

The process is finished and the quantity of parts is displayed.

or:

⇒ Change the piece quantity using  or  button.
The new piece quantity is displayed, e.g. „add50“.

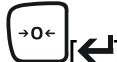
⇒ Place the indicated quantity of pieces and press the  button
The process is finished and the quantity of parts is displayed.

⇒ Press 

The balance returns to the weighing mode, the weighed piece quantity now will be deleted.



7.7.2 Piece counting by means of input piece weight

⇒ Press the  [←] button.

In the display appears the piece weight entered as last. The right-hand cipher flashes.

⇒ Press the  [←] button in order to use again the displayed piece weight. The weighed piece quantity is displayed.

or:

⇒ Change the piece weight using  [↑] or  [↓] button. The new piece weight will be displayed.

⇒ Press the  [←] button in order to use the new piece weight. The weighed piece quantity is displayed.

⇒ Press  button for approx. 3 seconds.

The balance returns to the weighing mode, the weighed piece quantity now will be deleted.

7.8 Adding

The display unit offers an option that allows the addition of weighings and the display of the total weight. When the tare weight is active, the net weight is automatically added up.

⇒ Loading the system with the load to be added

⇒ To add the weighed weight to the memory, press the  button.

In the display appears shortly „**AddEd**“.

Then the balance returns automatically into the weighing mode.

If the balance is connected to a printer, the displayed value will be printed out.

The gross, net and tare weights are added.

or:

⇒ To read the total weight calculated so far, press the  button for three seconds.

The display alternately displays for 3 seconds the consecutive numbers (number of weighings) and the total value of the weighings in the memory.

⇒ As long as the total value is displayed, press the  button for approx. 3 seconds.

The total value is printed out and at the same time the memory will be deleted.

⇒ As long as the total value is displayed, press the  button.

The memory is deleted without printing the total value.

If during the display no button is pressed, the subtotal will remain in the memory and the balance after approx. 60 seconds will automatically return to the weighing mode.

7.9 Weighing units switch-over

The balance has the possibility to switch over between the units kg and lb.

⇒ Press button .

The weight of the placed sample is displayed for 5 seconds, after that the balance returns automatically to the starting unit.

7.10 PRINTING

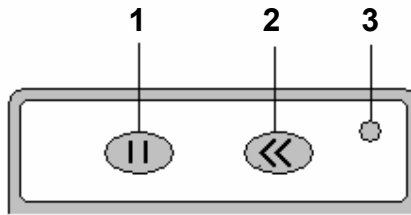

1. Interrupt the printing process
2. Paper forward feed, only if LED is lighting
3. LED, lights up during printing process

When the weighing system is equipped with a printer, current weighing data and entered data can be printed out. Date and time are only printed out, if this option has been installed.

⇒ Press  button.



⇒ A printout will be made. The current weight is added to the addition memory

- On the printout a **gross weight** with the letters „**B/G**“ and
- A **net weight** with the letters „**N**“ will be indicated.
- A manually entered **tare weight** will also be printed out and indicated by the characters „**PT**“.
- The **total weight** will be indicated by the characters „**TOT**“.

Example printout **without code**:

B/G	1234.5 kg
T	34.5 kg
N	1200.0 kg

No.	1
10/11/08	17:45

Example printout **with code**:

CODE	12345
B/G	1234.5 kg
T	34.5 kg
N	1200.0 kg

No.	1
10/11/08	17:45

Example piece counting printout **without code**:

B/G	1234.5 kg
T	34.5 kg
N	1200.0 kg

PcWt	1.234 kg
Qty	12345 PCs

No.	1
10/11/08	17:45

Example piece counting printout **with code**:

CODE	12345
B/G	1234.5 kg
T	34.5 kg
N	1200.0 kg

PcWt	1.234 kg
Qty	12345 PCs

No.	1
10/11/08	17:45

Example piece counting printout **always without code**:

Tot. B/G 1234.5 kg
Tot.T 34.5 kg
Tot.N 1200.0 kg

Tot.No. 999
10/11/08 17:45

7.11 PAPER CHANGE

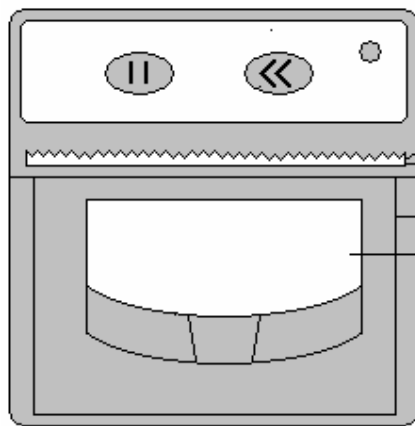

Thermal roll
Roll diameter max. 32 mm
Width 58 mm

- ⇒ Switch off the weighing system.
- ⇒ Pull the bracket until the cover plate opens; do not apply too much force in order to avoid damage.
- ⇒ Insert the paper roll, the loose side has to point forwards, over the printer.
- ⇒ Hold fast the loose side of the paper roll when the printer is being closed, so that the paper will remain visible when the printer is closed.

To close the printer:

- ⇒ Press on both sides of the cover plate at the same time.

or

- ⇒ Press on the center of the cover plate near the paper outlet.

In order to pull-off the paper correctly:

- ⇒ Pull the paper from one to the other side over the pull-off edge.

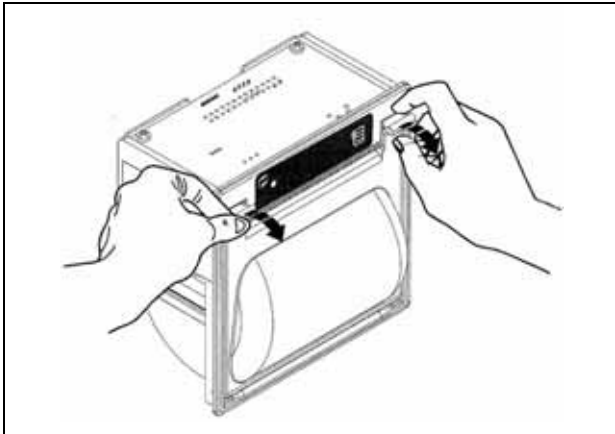

Open the paper flap by pressing downwards both locking clips and opening the printer cover.

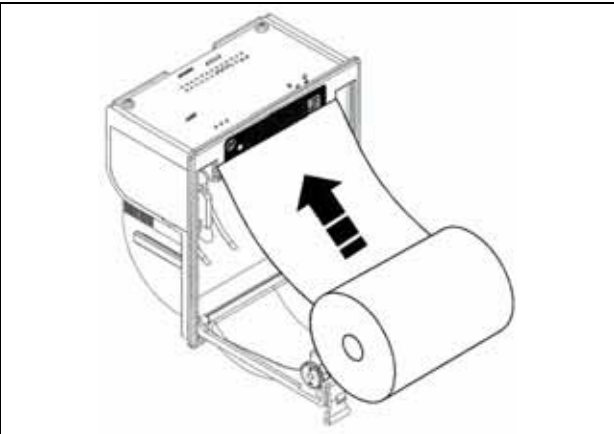

Remove the old paper roll and insert the new one as shown above, so that the roll is unspooled in the correct sense.

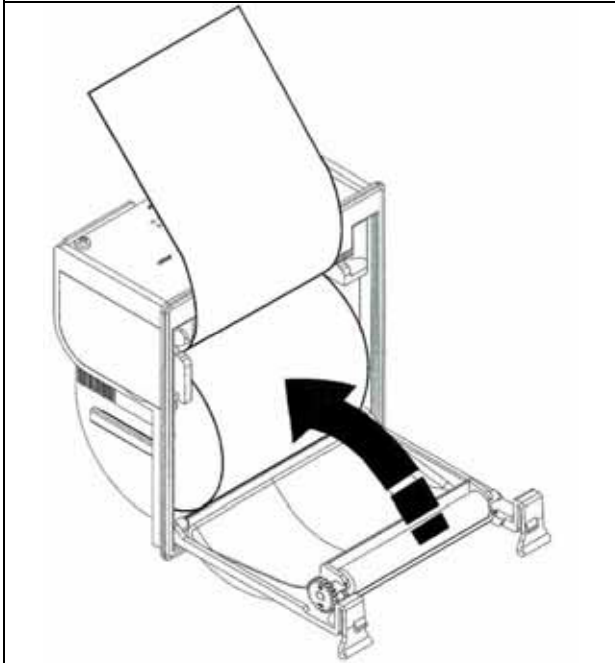

Unspool the roll a little and close the cover. Thereby hold fast the paper end at the upper edge of the printer.

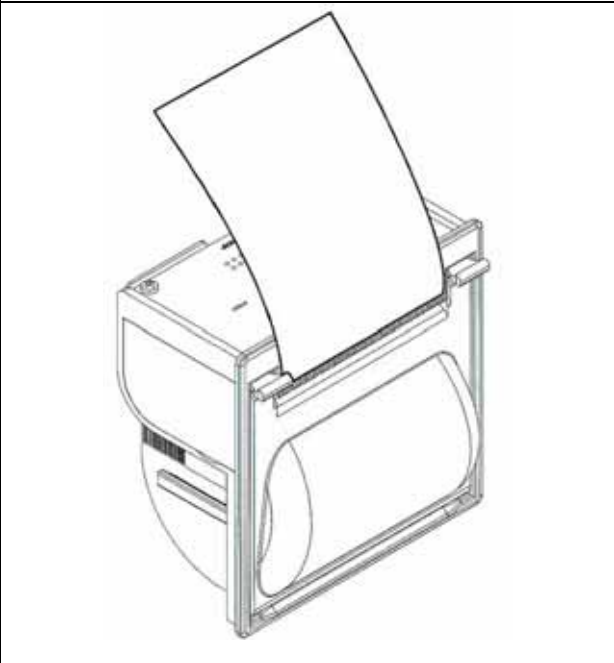

The roll change is finished, ready for printing.



7.12 Change of date and time on the printout



If the weighing system is equipped with a printer, data and time can be printed out with the weighing data.

⇒ Press the  [←] button for 6 seconds.
In the display appears „**ho_00**“ or the last **hours** setting.
The right number flashes.

⇒ Confirm value with  [←]

or:

⇒ Using  [↑] or  [↓] change the value increasing or decreasing until the desired value will be reached.

⇒ Use  [←] to change to the next cipher, and set the desired value also by means of  [↑] or  [↓] .

⇒ Use  [←] to confirm the desired **hours** setting.

In the display appears „**m_00**“ or the last **minutes** setting.

⇒ Set the desired value as described above.

In the display appears „**dA_00**“ or the last **day** setting.

⇒ Set the desired value

In the display appears „**m_00**“ or the last **month** setting.

⇒ Set the desired value

In the display appears „**YE_00**“ or the last **year** setting.

⇒ Set the desired value

The balance changes into weighing mode.

7.13 Set limit value

⇒ Press  [←]

On the display appears the limit value entered as last.
This function is not present in this model.

8 Service, maintenance, disposal

8.1 Cleaning

Please do not use aggressive cleaning agents (solvents or similar agents), but a cloth dampened with mild soap suds. Ensure that no liquid penetrates into the device and wipe with a dry soft cloth.

8.2 Service, maintenance

The appliance may only be opened by trained service technicians who are authorized by KERN.

The same maintenance guidelines apply to the chassis of the mobile weighing system as those for simple manual pallet trucks. Experience has taught us that the integrated weighing system continues to function even if the chassis was damaged by overloading.

General rules:

- As the steering wheels are mounted at the front, it is better to pull rather than push the manual pallet truck.
- If the lifting device is not used, the manual lever should be left in centre position. This prolongs the life span of the seals.
- To prevent damages to the electronic system and weighing cells it is necessary that welding work on the entire weighing system is carried out exclusively by technical specialists.
- The bearings of the wheels (with the exception of polyurethane) as well as the joints in the load roller section should be regularly cleaned and greased.

8.3 Disposal

Disposal of packaging and appliance must be carried out by operator according to valid national or regional law of the location where the appliance is used.

9 Error messages

Error	Possible cause	Remedy
Err01	Signal of the weighing cell unstable	Automatic
Err02	Balance overloaded	Automatic after unloading
Err03	Gross negative. This action is not allowed	Automatic
Err04	Outside the zero range	Press any button
Err05	Exactness of piece calculation insufficient	Press any button
Err06	Load cell signal too high	Automatically to correction and input
Err07	Load cell signal too low	Automatically to correction and input
Err08	Calibration outside the range (negative)	Automatic
Err09	Calibration outside the range (signal too low)	Automatic
Err10	Calibration value of the 2nd (3rd) point lower than the value of the 1st (2nd) point	Automatic
Err11	Calibration from piece counting mode	Automatic
Err97	Calibration blocked	Automatic
Err98	The calibration value must be higher than the previous one	Automatic
Err99	Actuation only allowed on the display device	Automatic

10 Instant help

In case of an error in the program process, briefly turn off the balance and disconnect from power supply. The weighing process must then be restarted from the beginning.

Help:

Fault

Possible cause

The displayed weight does not glow.

- The balance is not switched on.
- The batteries are empty

The displayed weight is permanently changing

- Draught/air movement

-

- Sites with vibration.
- Loading fork is in contact with foreign matter.
- Electromagnetic fields / static charging (choose different location/switch off interfering device if possible)

The weighing value is obviously wrong

- The display of the balance is not at zero
- Adjustment is no longer correct.
- Great fluctuations in temperature.
- Electromagnetic fields / static charging (choose different location/switch off interfering device if possible)

Should other error messages occur, switch balance off and then on again. If the error message remains inform manufacturer.