



KERN & Sohn GmbH

Ziegelei 1

D-72336 Balingen

E-Mail: info@kern-sohn.com

Phone: +49-[0]7433- 9933-0

Fax: +49-[0]7433-9933-149

Internet: www.kern-sohn.com

Operating instructions

Pallet truck scales

KERN VHE-N

Version 2.0

10/2011

GB



VHE-N-BA-e-1120



KERN VHE-N

Version 2.0 10/2011

Operating instructions Pallet truck scale

Contents

1	Technical data	3
1.1	Dimensions	4
2	Appliance overview	5
2.1	Overview of display	5
2.2	Keyboard overview	6
2.2.1	In weighing mode	6
3	Basic instructions for scales	7
3.1	Proper use	7
3.2	Improper Use	7
3.3	Warranty	7
3.4	Monitoring of Test Resources	8
4	Basic safety instructions for scales	8
4.1	Pay attention to the instructions in the Operation Manual	8
4.2	Personnel training	8
5	Transport and storage	8
5.1	Testing upon acceptance	8
5.2	Packaging / return transport	8
6	Unpacking and placing	9
6.1	Site of installation, place of operation for scales	9
6.2	Scope of delivery	10
7	Commissioning	11
7.1	Switch on pallet truck scale	12
7.2	Switch off pallet truck scale	12
7.3	Weighing	13
7.4	Zero point correction	14
7.5	Taring	14
7.6	Totalization	15
7.7	Display of the saved weighing data:	15
7.8	Delete the stored weighing data	15
7.9	Battery operation	16
8	Error messages	17
9	Service, maintenance, disposal	18
9.1	Clean	18
9.2	Service, maintenance	18
9.3	Disposal	18
10	Instant help	19

1 Technical data

KERN	VHE 2T5N
Readability (d)	5 kg
Weighing range (max)	2200 kg
Reproducibility	10 kg
Linearity	± 10 kg
Stabilization time	3 sec.
Allowable ambient temperature	-10° C + 40° C
Humidity of air	max. 95 % (not condensing)
Weighing unit	kg
Electric Supply	4 x 1.5V AA batteries
Operating period	80 h
Auto Off	3 min
Net weight	60 kg

1.1 Dimensions

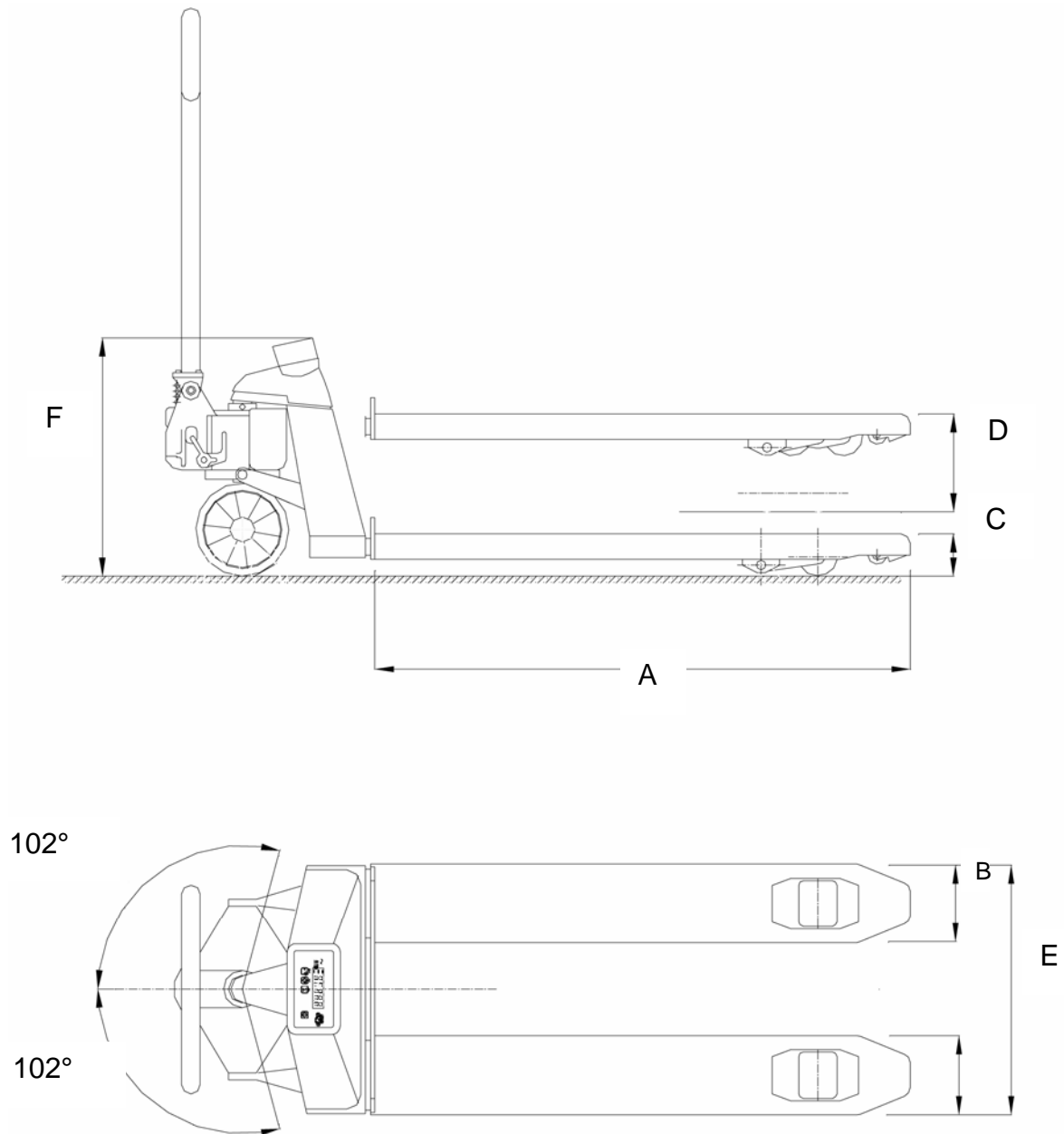





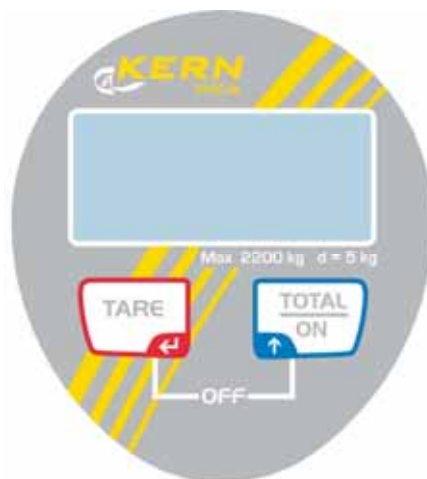

A	Fork length	1150 mm
B	Fork width	150 mm
C	Minimum fork height	83 mm
	Clearance	30 mm
D	Maximum fork height	205 mm
	Hoisting height	122 mm
E	Width across forks	520 mm
F	Height upper edge of display	575 mm

2 Appliance overview



2.1 Overview of display



	Load too high lifted; the upper arrow flashes
	Reference height reached
	Reference height almost reached, very slow lifting, 1 arrow illuminated
	Slow lifting, 2 arrows illuminated
	Fast lifting, 3 arrows illuminated
	The displayed weight value is negative
M	Weight is saved
KG	Weight value in kg
	Batteries of the display unit are empty; exchange batteries

2.2 Keyboard overview

2.2.1 In weighing mode

Operation		
Short key pressing	<ul style="list-style-type: none"> • Zeroing 	<ul style="list-style-type: none"> • Switch on balance • Add weight to sum memory
Button pressed for a long time (>3 sec)		<ul style="list-style-type: none"> • Call up subtotal
Button pressed for a very long time (>10 sec)	<ul style="list-style-type: none"> • Delete memory 	
Press both buttons for approx. 2 sec	<ul style="list-style-type: none"> • Turn off system 	

3 Basic instructions for scales

3.1 Proper use

The balance you purchased is intended to determine the weighing value of material to be weighed. It is intended to be used as a “non-automatic balance”, i.e. the material to be weighed is manually and carefully placed in the centre of the weighing pan.. As soon as a stable weighing value is reached the weighing value can be read.

3.2 Improper Use

Do not use balance for dynamic weighings. In the event that small quantities are removed or added to the material to be weighed, incorrect weighing results can be displayed due to the “stability compensation“. (Example: Slowly draining fluids from a container on the balance.)

Do not leave permanent load on the weighing pan. This may damage the measuring system.

Impacts and overloading exceeding the stated maximum load (max) of the balance, minus a possibly existing tare load, must be strictly avoided. Balance may be damaged by this.

Never operate balance in explosive environment. The serial version is not explosion protected.

The structure of the balance may not be modified. This may lead to incorrect weighing results, safety-related faults and destruction of the balance.

The balance may only be used according to the described conditions. Other areas of use must be released by KERN in writing.

3.3 Warranty

Warranty claims shall be voided in case

- Our conditions in the operation manual are ignored
- The appliance is used outside the described uses
- The appliance is modified or opened
- Mechanical damage and damage caused by media, liquids
- Natural wear and tear
- The appliance is improperly set up or incorrectly electrically connected
- The measuring system is overloaded

3.4 Monitoring of Test Resources

In the framework of quality assurance the measuring-related properties of the balance and, if applicable, the testing weight, must be checked regularly. The responsible user must define a suitable interval as well as type and scope of this test. Information is available on KERN's home page (www.kern-sohn.com) with regard to the monitoring of balance test substances and the test weights required for this. In KERN's accredited DKD calibration laboratory test weights and balances may be calibrated (return to the national standard) fast and at moderate cost.

4 Basic safety instructions for scales

4.1 Pay attention to the instructions in the Operation Manual

	Carefully read this operation manual before setup and commissioning, even if you are already familiar with KERN balances.
---	---

4.2 Personnel training

The appliance may only be operated and maintained by trained personnel.

5 Transport and storage

5.1 Testing upon acceptance

When receiving the appliance, please check packaging immediately, and the appliance itself when unpacking for possible visible damage.

5.2 Packaging / return transport



- ⇒ Keep all parts of the original packaging for a possibly required return.
- ⇒ Only use original packaging for returning.

6 Unpacking and placing

6.1 Site of installation, place of operation for scales

The balances are designed in a way that reliable weighing results are achieved in common conditions of use.

You will work accurately and fast, if you select the right location for your balance.

On the installation site observe the following:

- The load must be lifted clear of the display unit's case and other pallets.

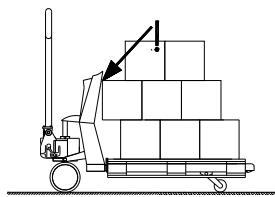

Incorrect lifting of a load

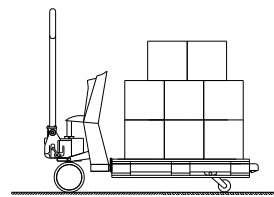

Correct lifting of a load

- The load must be lifted evenly distributed, so that it has the lowest measurement insecurity (deviations up to 0.8% of the capacity may occur).
- Inclined position of the weighing system can falsify the weighing result. Holes and unevenness, too, have this effect. A smooth floor is ideal.

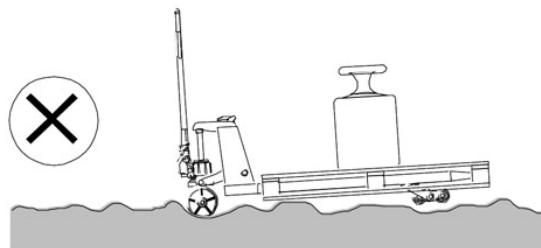
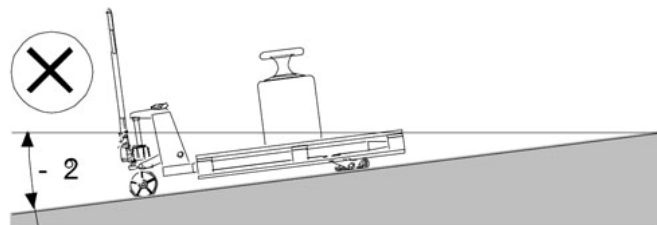

- Optimum accuracy in weighing results is achieved if the load centre is between the forks. The forks are easily bent and twisted when the load is off-centre. This may result in diminished accuracy.

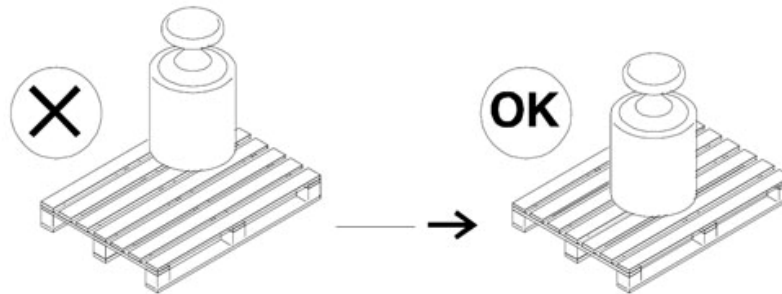

- Avoid jarring during weighing
- Protect the balance against high humidity, vapours and dust

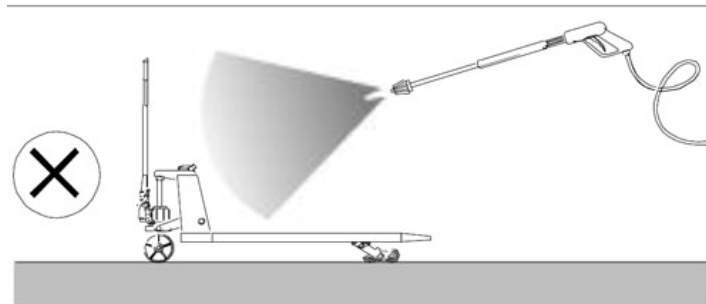

- Do not expose the device to extreme dampness for longer periods of time. Non-permitted condensation (condensation of air humidity on the appliance) may occur if a cold appliance is taken to a considerably warmer environment. In this case, acclimatize the disconnected appliance for ca. 2 hours at room temperature.
- Major display deviations (incorrect weighing results) may be experienced should electromagnetic fields (e.g. due to mobile phones or radio equipment), static electricity accumulations or instable power supply occur. Change location or remove source of interference.

6.2 Scope of delivery

Serial accessories:

- Pallet truck scales
- 2 x 1.5V AA batteries
- Operating instructions

7 Commissioning



**Correct weighing only possible at „reference height“
(see fig. 1 and 2)**

⇒ Actuate repeatedly the lifting device (hand lever **1** downwards, fig.1) until the reference height is reached. In the display appears  see fig.2.



fig. 1



fig. 2

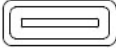



- ⇒ If the pallet truck scale is not at reference height, the weight value will be appear flashing in the display.
- ⇒ Bring pallet truck scale to reference height, the display does not more flash.

7.1 Switch on pallet truck scale









<p>⇒ Press  to switch on the pallet truck scale, the balance will execute a self-test and then changes to the zero display.</p>	<p>88888 kg 0 kg</p>
--	--

7.2 Switch off pallet truck scale



<p>⇒ Press buttons  and  for approx. 2 sec</p>	<p>22 kg (Example)</p>
<p>The display will disappear.</p>	

	<p>⇒ The display will extinguish automatically, if the buttons are not pressed for 2 minutes or the system is not used.</p>
---	---



7.3 Weighing

<p>⇒ Press  to switch on the pallet truck scale, the balance will execute a self-test and then changes to the zero display. „0“ will appear flashing.</p> <p>If „0“ is not displayed, press .</p>	<p>88888 kg</p> <p>0 kg</p>
<p>⇒ Lower the pallet truck scale to the lowest point. Three arrows will light up when the lowest point is reached.</p>	<p> 0 kg</p>
<p>⇒ Take up the load and lift it till to reference height. Three arrows will light up. The weight value will be displayed flashing. Continue to lift the load.</p>	<p> 250 kg (Example)</p>
<p>⇒ Two arrows will light up. Slow lifting</p>	<p> 250 kg (Example)</p>
<p>⇒ One arrow will light up. Slow lifting.</p>	<p> 250 kg (Example)</p>
<p>The reference height is reached. The  symbol pops up. The display of the weight value does not more flash.</p>	<p> 250 kg (Example)</p>
<p>The upper arrow is lit up when the load has been taken up too high. Lower the pallet truck scale completely till to the floor to restart another weighing.</p>	<p> 250 kg (Example)</p>

7.4 Zero point correction



<p>⇒ Switch on pallet truck scale using  button.</p>	
<p>⇒ Check if the forks of the pallet truck scale are empty</p> <p>⇒ Lift pallet truck scale till to the reference height (see chap. 7, fig. 1).</p> <p>⇒ If the display does not show zero, reset the display using </p>	<p>0 kg</p>

7.5 Taring

<p>⇒ Lift weighing container till to the reference height (see chap. 7, fig. 1).</p>	
<p>⇒ Switch on pallet truck scale using  button. The weight of the weighing container is displayed.</p>	<p>50 kg (Example)</p>
<p>⇒ Tare using  button.</p> <p>⇒ Fill material to be weighed in the container, the net weight is displayed.</p>	<p>0 kg</p> <p>100 kg (Example)</p>
<p>⇒ If the container is removed from the balance, the tare weight is displayed as a negative value. The tare weight remains stored until the  button is pressed anew or the balance is switched off.</p>	<p>-100 kg</p>

7.6 Totalization

The display unit offers an option that allows the addition of weighing values and the display of the total weight.

⇒ Take up load and bring it to reference height	 250 kg (Example)
⇒ Press  . The value is stored and „M“ will be displayed. In the display appear alternately the continuous number (number of weighings) and the total weight. After a few seconds the system automatically reverts to standard weighing mode.	 250 M kg (Example)
⇒ Add another load is described before. Please note that the system must be unloaded between the individual weighing procedures.	

7.7 Display of the saved weighing data:

⇒ Press  for approx. 3 sec, the number of individual weighings and the total weight are displayed alternately

7.8 Delete the stored weighing data

⇒ Press  shortly, the data in the memory are deleted, the display changes automatically into weighing mode and the “M” extinguishes.

7.9 Battery operation

Power is supplied via 2 x 1.5V AA batteries. At a regular use with full batteries, approx. 1 year can be weighed.

If the battery symbol  is displayed, this means that the batteries will soon be flat.

Change the batteries immediately.

If the capacity of the batteries is completely exhausted, the display will switch-off automatically.

In order to save the battery, the balance switches automatically off after 3 minutes without load changing.

If the balance is not used for a longer time, take out the batteries and store them separately. Leaking battery liquid could damage the balance.

Change the battery as follows:

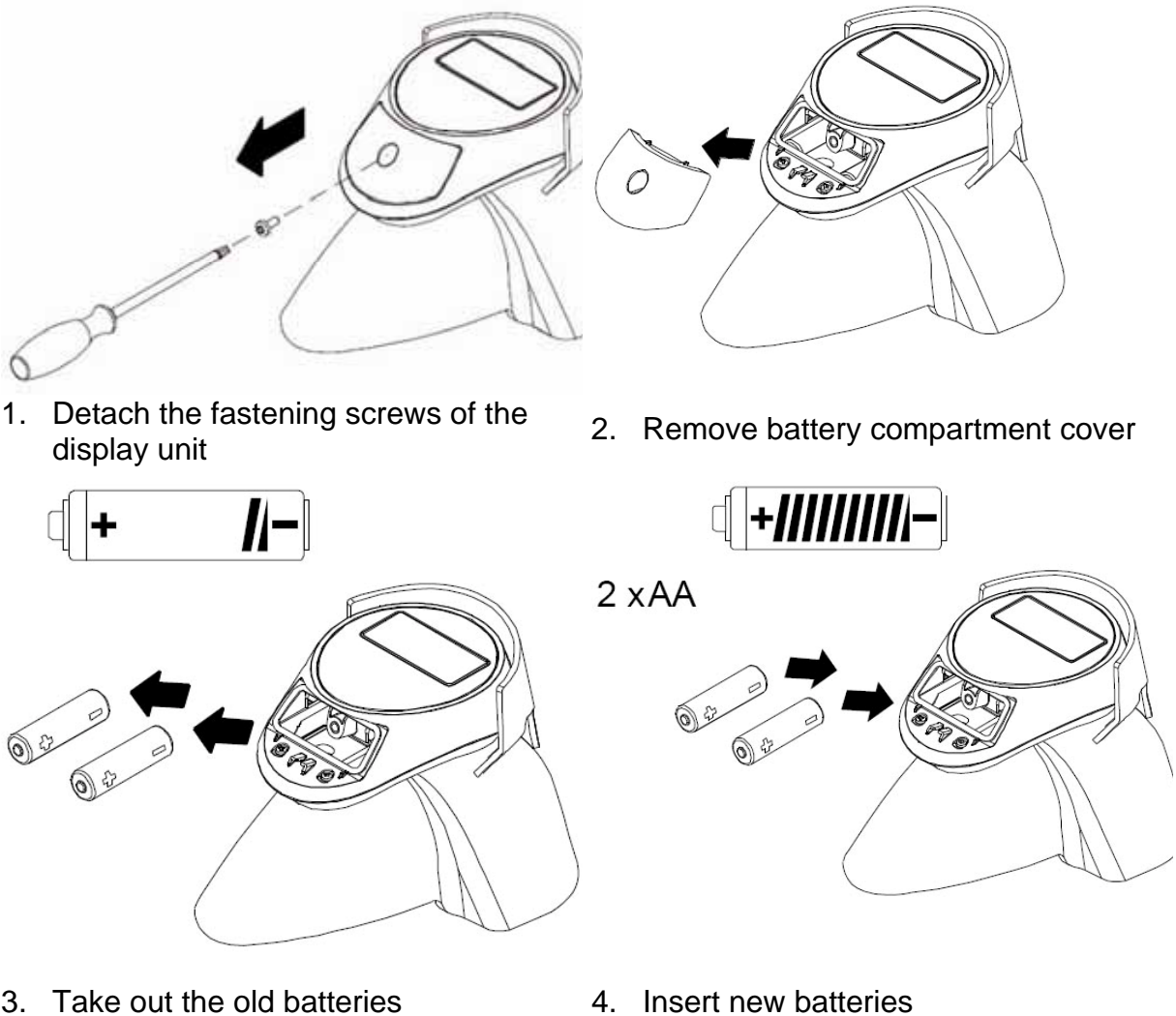

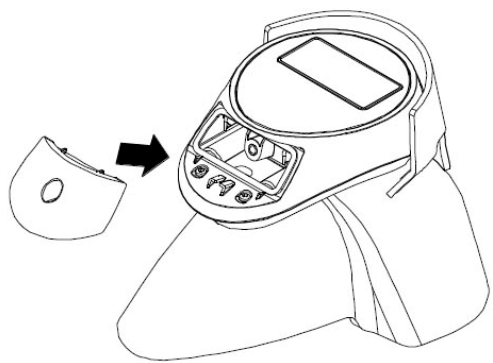

5. Place the battery compartment cover

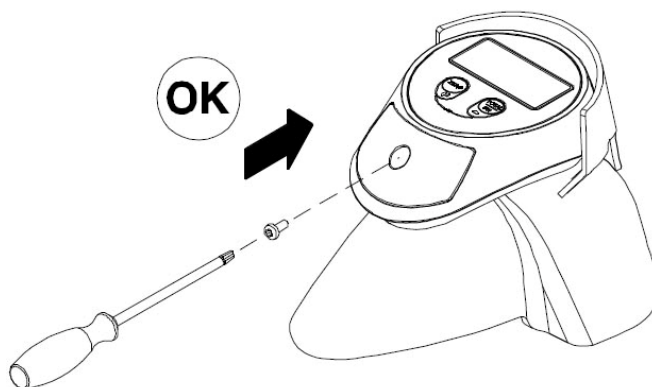

6. Screw-in the fastening screw of the display unit

8 Error messages

- O.L. -	The weighing system is overloaded. Remove the load
Err06	Load cell signal too high
Err07	Load cell signal too low
Err12	Calibration deleted
Err98	Calibration value must be higher than the former value
	Battery symbol flashes: The battery is almost empty and needs to be replaced (see chap. 7.9)
M	Flashing „M“: Memory is full, no weights can be added. Delete memory (see chap. 7.8)

9 Service, maintenance, disposal

9.1 Clean

Please do not use aggressive cleaning agents (solvents or similar agents), but a cloth dampened with mild soap suds. Take care that the device is not penetrated by fluids and polish it with a dry soft cloth.

9.2 Service, maintenance

The appliance may only be opened by trained service technicians who are authorized by KERN.

The same maintenance guidelines as for standard manual lift truck without load-display system.

General rules:

- Pulling instead of pushing allows an easier handling of the load (steering wheels on the side of the drawbar)
- If the lifting device is not used, the manual lever should be left in centre position. This prolongs the life span of the seals.
- The display unit should only be cleaned with a damp cloth. Chemical cleaning agents and a pressurized water jet cause damage.
- To prevent damages to the electronic system and weighing cells it is necessary that welding work on the entire weighing system is carried out exclusively by technical specialists.
- The bearings of the wheels as well as the joints in the load roller section should be regularly cleaned and greased.

9.3 Disposal

Disposal of packaging and appliance must be carried out by operator according to valid national or regional law of the location where the appliance is used.

10 Instant help

In case of an error in the program process, briefly turn off the balance and disconnect from power supply. The weighing process must then be restarted from the beginning.

Help:

Fault

Possible cause

The displayed weight does not glow.

- The balance is not switched on.
- The batteries are empty

The displayed weight is permanently changing

- Draught/air movement
- Sites with vibration.
- Loading fork is in contact with foreign matter.
- Electromagnetic fields / static charging (choose different location/switch off interfering device if possible)

The weighing value is obviously wrong

- The display of the balance is not at zero
- Adjustment is no longer correct.
- Great fluctuations in temperature.
- Electromagnetic fields / static charging (choose different location/switch off interfering device if possible)
- Load fork was not pumped to reference height
- The control pin is not in „Reference height“ position.

Should other error messages occur, switch balance off and then on again. If the error message remains inform manufacturer.