



KERN PLS/PLJ/ALS/ALJ

Version 1.9 03/2008

Operating Instructions

Electronic precision and analytical balance

Contents

1	Technical Data	37
2	Declaration of conformity	41
3	Fundamental information (general)	43
3.1	Intended Use	43
3.2	Inappropriate use	43
3.3	Guarantee	43
3.4	Monitoring the test substances	44
4	Fundamental safety information	44
4.1	Observe the information in the operating instructions	44
5	Transport and storage	44
5.1	Acceptance check	44
5.2	Packaging	44
6	Unpacking, installation and commissioning	45
6.1	Place of installation, place of use	45
6.2	Unpacking	45
6.2.1	Installation	46
6.2.2	List of items supplied	47
6.3	Mains supply	47
6.4	Connection of peripheral equipment	47
6.5	Initial start-up	47
6.5.1	Power display	47
6.5.2	Stability display	47
6.5.3	Balance zero-display	48
6.5.4	Auto-zero-function	48
6.6	Adjustment	48
6.6.1	Adjusting with internal weight (only PLJ/ALJ)	49
6.7	Adjusting with external weight (only PLS/ALS)	49
6.8	Verification	50
6.9	Under floor weighing	51

7	Operation	52
7.1	Operating elements	52
7.1.1	Rear illuminated Display	52
7.1.2	Keyboard:	53
7.2	Weighing	54
7.2.1	Simple weighing	54
7.2.2	Weighing Units	54
7.3	Taring	56
7.4	Adding of display values (only PLJ)	56
7.5	Parts counting	58
7.6	Percentage determination	59
7.6.1	Determination of a reference weight by weighing	59
7.6.2	Determination of a reference weight by numeric entry	60
8	Functions	61
8.1	Weighing functions	61
8.2	General functions	62
8.3	Parameter for the serial interface	63
9	Data output RS 232 C	64
9.1	Technical Data	64
9.2	Pin allocation of the balance exit plug (front view)	64
9.3	Interface cables	64
9.4	Description of the data transfer (data format)	65
9.4.1	Output when pressing the PRINT-button	65
9.4.2	Remote commands	65
9.4.3	Output format	66
10	Maintenance, upkeep, disposal	67
10.1	Cleaning	67
10.2	Maintenance, upkeep	67
10.3	Disposal	67
11	Troubleshooting	68

1 Technical Data

KERN	ALS 120-4	ALS 220-4	ALJ 120-4
<i>Readability (d)</i>	0.1 mg	0.1 mg	0.1 mg
<i>Weighing range (Max)</i>	120 g	220 g	120 g
<i>Taring range (subtractive)</i>	120 g	220 g	120 g
<i>Reproducibility</i>	0.2 mg	0.2 mg	0.2 mg
<i>Linearity</i>	± 0.2 mg	± 0.2 mg	± 0.2 mg
<i>Minimal piece weight for Parts counting</i>	> 0.5 mg	> 0.5 mg	> 0.5 mg
<i>Recommended adjusting weight, not included (class)</i>	100 g (E2)	200 g (E2)	internal
<i>Warming up time (operating temperature)</i>	8 h		
<i>Verifiable</i>	no		
<i>Reference piece numbers for Parts counting</i>	10, 20, 50, freely selectable		
<i>Weighing Units</i>	mg, g, ct, gn, mom, oz, dwt		
<i>Stabilization time (typically)</i>	4 sec.		
<i>Permissible ambient temperature</i>	+ 15° C +30° C		
<i>Humidity of air</i>	max. 80 % (not condensing)		
<i>Under floor weighing device</i>	Loop for under floor weighing, serial		
<i>Housing (W x D x H) mm</i>	206 x 312 x 260		
<i>Weighing plate mm</i>	85		
<i>Weight kg (net)</i>	6,3		

KERN	ALJ 220-4	ALJ 160-4M	ALJ 220-4M
<i>Readability (d)</i>	0,1 mg	0,1 mg	0,1 mg
<i>Weighing range (Max)</i>	220 g	160 g	220 g
<i>Minimum load (Min)</i>	-	10 mg	10 mg
<i>Taring range (subtractive)</i>	220 g	160 g	220 g
<i>Reproducibility</i>	0,2 mg	0,2 mg	0,2 mg
<i>Linearity</i>	± 0,2 mg	± 0,2 mg	± 0,2 mg
<i>Minimal piece weight for Parts counting</i>	> 0,5 mg	> 0,5 mg	> 0,5 mg
<i>Adjustment weight</i>	<i>internal</i>	<i>internal</i>	<i>internal</i>
<i>Verifiable</i>	<i>no</i>	<i>yes</i>	<i>yes</i>
<i>Verification value (e)</i>	-	1 mg	1 mg
<i>Accuracy category</i>	-	<i>I</i>	<i>I</i>
<i>Warming up time (operating temperature)</i>	8 h		
<i>Reference piece numbers for parts counting</i>	10, 20, 50, freely selectable		
<i>Weighing Units</i>	<i>mg, g, ct, gn, mom, oz, dwt</i>	<i>mg, g, ct</i>	
<i>Stabilization time (typically)</i>	4 sec.		
<i>Permissible ambient temperature</i>	+ 18° C + 30° C		
<i>Humidity of air</i>	<i>max. 80 % (not condensing)</i>		
<i>Under floor weighing device</i>	<i>Loop for under floor weighing, serial</i>		
<i>Weighing plate mm</i>	206 x 312 x 260		
<i>Housing (W x D x H) mm</i>	85		
<i>Weight kg (net)</i>	6,3		

KERN	PLS 360-3	PLS 510-3	PLS2100-2	PLS 4000-2
<i>Readability (d)</i>	0.001 g	0.001 g	0.01 g	0.01 g
<i>Weighing range (Max)</i>	360 g	510 g	2,100 g	4,000 g
<i>Taring range (subtractive)</i>	360 g	510 g	2,100 g	4,000 g
<i>Reproducibility</i>	0.002 g	0.002 g	0.02 g	0.02 g
<i>Linearity</i>	± 0.002 g	± 0.002 g	± 0.02 g	± 0.02 g
<i>Minimal piece weight for Parts counting</i>	> 0.005 g	> 0.005 g	> 0.05 g	> 0.05 g
<i>Recommended adjusting weight, not included (class)</i>	200 g (F1)	500 g (E2)	2000 g (F1)	2000 g (F1)
<i>Verifiable</i>	no	no	no	no
<i>Warming up time (operating temperature)</i>	2 h	4 h	2 h	4 h
<i>Reference piece numbers for parts counting</i>	10, 20, 50, freely selectable			
<i>Weighing Units</i>	mg, g, ct, gn, mom, oz, dwt			
<i>Stabilization time (typically)</i>	4 sec.			
<i>Permissible ambient temperature</i>	+ 15° C +30° C			
<i>Humidity of air</i>	max. 80 % (not condensing)			
<i>Under floor weighing device</i>	Loop for under floor weighing, serial			
<i>Weighing plate mm</i>	128 x 128		165 x 165	
<i>Housing (W x D x H) mm</i>	206 x 312 x 160 (with draft shield)		206 x 312 x 98 (without draft shield)	
<i>Weight kg (net)</i>	4,6		5,4	

KERN	PLJ 360-3M	PLJ 510-3M	PLJ 2100-2M	PLJ 4000-2M	PLJ 6100-2
Readability (d)	0.001 g	0.001 g	0.01 g	0.01 g	0.01 g
Weighing range (Max)	360 g	510 g	2,100 g	4,000 g	6,100 g
Minimum load (Min)	0,02 g	0,02 g	0,5 g	0,5 g	-
Taring range (subtractive)	360 g	510 g	2,100 g	4,000 g	6,100 g
Reproducibility	0.002 g	0.002 g	0.02 g	0.02 g	0.01 g
Linearity	± 0.002 g	± 0.002 g	± 0.02 g	± 0.02 g	± 0.03 g
Minimal piece weight for Parts counting	> 0.05 g	> 0.005 g	> 0.05 g	> 0.05 g	> 0.05 g
Adjustment weight	internal	internal	internal	internal	internal
Verifiable	yes	yes	yes	yes	no
Verification value (e)	0.01 g	0.01 g	0.1 g	0.1 g	-
Accuracy category	II	II	II	II	-
Warming up time (operating temperature)	2 h	4 h	2 h	4 h	4 h
Reference piece numbers for parts counting	10, 20, 50, freely selectable				
Weighing Units	mg, g, ct,				mg, g, ct, gn, mom, oz, dwt
Stabilization time (typically)	4 sec.				
Permissible ambient temperature	+ 15° C +30° C				
Humidity of air	max. 80 % (not condensing)				
Under floor weighing device	Loop for under floor weighing, serial				
Weighing plate mm	128 x 128		165 x 165		
Housing (W x D x H) mm	206 x 312 x 160 (with draft shield)		206 x 312 x 98 (without draft shield)		
Weight kg (net)	4,6		5,4		

2 Declaration of conformity



KERN & Sohn GmbH

D-72322 Balingen-Frommern

Postfach 4052

E-Mail: info@kern-sohn.de

Tel: 0049-[0]7433- 9933-0

Fax: 0049-[0]7433-9933-149

Internet: www.kern-sohn.de

Konformitätserklärung

Declaration of conformity for apparatus with CE mark

Konformitätserklärung für Geräte mit CE-Zeichen

Déclaration de conformité pour appareils portant la marque CE

Declaración de conformidad para aparatos con marca CE

Dichiarazione di conformità per apparecchi contrassegnati con la marcatura CE

- English** We hereby declare that the product to which this declaration refers conforms with the following standards.
- Deutsch** Wir erklären hiermit, dass das Produkt, auf das sich diese Erklärung bezieht, mit den nachstehenden Normen übereinstimmt.
- Français** Nous déclarons avec cela responsabilité que le produit, auquel se rapporte la présente déclaration, est conforme aux normes citées ci-après.
- Español** Manifestamos en la presente que el producto al que se refiere esta declaración está de acuerdo con las normas siguientes
- Italiano** Dichiariamo con ciò che il prodotto al quale la presente dichiarazione si riferisce è conforme alle norme di seguito citate.

Electronic Balance: KERN ALS, ALJ KERN PLS, PLJ

Mark applied	EU Directive	Standards
	89/336EEC EMC	EN 61000-4-2 :1999 EN 61000-4-3 :1996 EN 61000-4-4 : 1999 EN 61000-4-5 : 1998 EN 61000-4-6 : 1999 EN 61000-4-11 : 1997 EN 55022 :2000

Date: 22.12.2005

Signature: 

Gottl. KERN & Sohn GmbH
Management

Gottl. KERN & Sohn GmbH, Ziegelei 1, D-72336 Balingen, Tel. +49-[0]7433/9933-0, Fax +49-[0]7433/9933-149



KERN & Sohn GmbH

D-72322 Balingen-Frommern

Postfach 4052

E-Mail: info@kern-sohn.de

Tel: 0049-[0]7433- 9933-0

Fax: 0049-[0]7433-9933-149

Internet: www.kern-sohn.de

Konformitätserklärungen

Declaration of conformity for apparatus with CE mark

Konformitätserklärung für Geräte mit CE-Zeichen

Déclaration de conformité pour appareils portant la marque CE

Declaración de conformidad para aparatos con marca CE

Dichiarazione di conformità per apparecchi contrassegnati con la marcatura CE

- English** We hereby declare that the product to which this declaration refers conforms with the following standards.
This declaration is only valid with the certificate of conformity by a notified body.
- Deutsch** Wir erklären hiermit, dass das Produkt, auf das sich diese Erklärung bezieht, mit den nachstehenden Normen übereinstimmt.
Diese Erklärung gilt nur in Verbindung mit der Konformitätsbescheinigung einer benannten Stelle.
- Français** Nous déclarons avec cela responsabilité que le produit, auquel se rapporte la présente déclaration, est conforme aux normes citées ci-après.
Cette déclaration est valide seulement avec un certificat de conformité d'un organisme notifié.
- Español** Manifestamos en la presente que el producto al que se refiere esta declaración está de acuerdo con las normas siguientes.
Esta declaración solo será válida acompañada del certificado de conformidad de conformidad de la parte nominal.
- Italiano** Dichiariamo con ciò che il prodotto al quale la presente dichiarazione si riferisce è conforme alle norme di seguito citate.
Questa dichiarazione sarà valida solo se accompagnata dal certificato di conformità della parte nominale.

Model: KERN ALJ/PLJ

EU Directive	Standards	EC-type-approval certificate no.	Issued by	Model
90/384/EEC	EN 45501	T6656	NMI	PLJ 360-3M PLJ 510-3M PLJ 2100-2M PLJ 4000-2M
		TCM 128/06-4438	CMI	ALJ 160-4M ALJ 220-4M

Date: 15.9.2006

Signature:

Gottl. KERN & Sohn GmbH
Management

Gottl. KERN & Sohn GmbH, Ziegelei 1, D-72336 Balingen, Tel. +49-07433/9933-0, Fax +49-074433/9933-149

3 Fundamental information (general)

3.1 Intended Use

The balance you have acquired serves to determine the weighing value of the material to be weighed. It is intended to be used as a “non-automatic“ balance, i.e. the material to be weighed is manually and carefully placed in the centre of the weighing plate. The weighing value can be read off after a stable weighing value has been obtained.

3.2 Inappropriate use

Do not use the balance for dynamic weighing. In the event that small quantities are removed or added to the material to be weighed, incorrect weighing results can be displayed due to the “stability compensation“ in the balance. (Example: Slowly draining fluids from a container on the balance.)

Do not leave a permanent load on the weighing plate. This can damage the measuring system.

Be sure to avoid impact shock and overloading the balance in excess of the prescribed maximum load rating (max.), minus any possible tare weight that is already present. This could cause damage to the balance.

Never operate the balance in hazardous locations. The series design is not explosion-proof.

Structural alterations may not be made to the balance. This can lead to incorrect weighing results, faults concerning safety regulations as well as to destruction of the balance.

The balance may only be used in compliance with the described guidelines. Varying areas of application/planned use must be approved by KERN in writing.

3.3 Guarantee

The guarantee is not valid at the following:

- non-observation of our guidelines in the operating instructions
- use outside the described applications
- alteration to or opening of the device
- mechanical damage and damage caused by media, liquids, natural wear and tear
- inappropriate erection or electric installation
- overloading of the measuring equipment

3.4 Monitoring the test substances

The metrology features of the balance and any possible available adjusting weight must be checked at regular intervals within the scope of quality assurance. For this purpose, the answerable user must define a suitable interval as well as the nature and scope of this check. Information is available on KERN's home page (www.kern-sohn.com) with regard to the monitoring of balance test substances and the test weights required for this. Test weights and balances can be adjusted quickly and at a reasonable price in KERN's accredited DKD calibration laboratory (return to national normal).

4 Fundamental safety information

4.1 Observe the information in the operating instructions

Please read the operating instructions carefully before erecting and commissioning, even if you already have experience with KERN balances.

4.2 Staff training

The device may only be operated and looked after by trained members of staff.

5 Transport and storage

5.1 Acceptance check

Please check the packaging immediately upon delivery and the device during unpacking for any visible signs of external damage.

5.2 Packaging

Please retain all parts of the original packaging in case it should be necessary to return items at any time.

Only the original packaging should be used for return consignments.

Before despatch, disconnect all attached cables and loose/movable parts.

Apply any intended transport security devices. Secure all parts e.g. weighing plate, mains power supply etc. against slipping and damage.

6 Unpacking, installation and commissioning

6.1 Place of installation, place of use

The balance is constructed in such a way that reliable weighing results can be achieved under normal application conditions.

By selecting the correct location for your balance, you will be able to work quickly and precisely.

Therefore please observe the following at the place of installation:

- Place the balance on a firm, level surface;
- Avoid extreme heat as well as temperature fluctuation caused by installing next to a radiator or in the direct sunlight;
- Protect the balance against direct draughts due to open windows and doors;
- Avoid jarring during weighing;
- Protect the balance against high humidity, vapours and dust;
- Do not expose the device to extreme dampness for longer periods of time. Inadmissible bedewing (condensation of air moisture on the device) can occur if a cold device is taken into a significantly warmer environment. In this case, please acclimatise the device for approx. 2 hours at room temperature after it has been disconnected from the mains.
- Avoid static charging of items to be weighed, or weighing container.

Major display deviations (incorrect weighing results) are possible if electromagnetic fields occur as well as due to static charging, currents and instable power supply. It is then necessary to change the location.

6.2 Unpacking

Carefully remove the balance from its packaging, remove the plastic wrapping and position the balance in its intended working location.

6.2.1 Installation

Use the foot screws to level the balance until the air bubble in the bubble level is in the prescribed circle.

Analysing balances (ALS/ALJ):

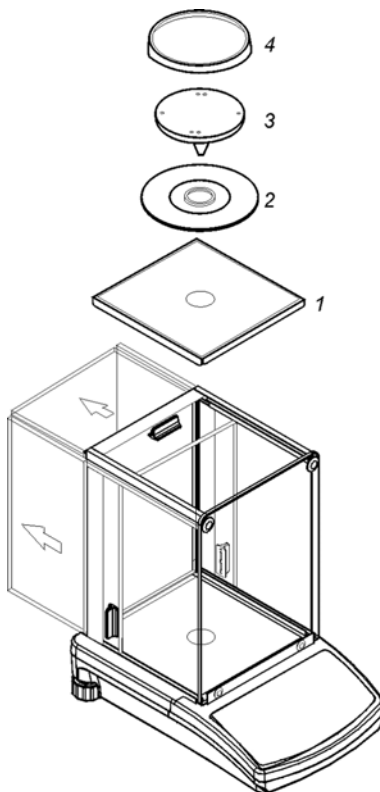

Precision balances (PLS/PLJ):

Models d = 10 mg

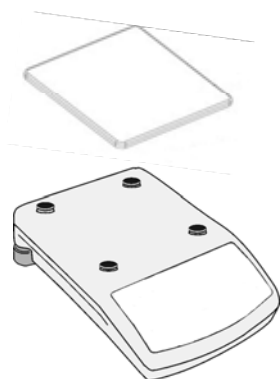

Models d = 1 mg

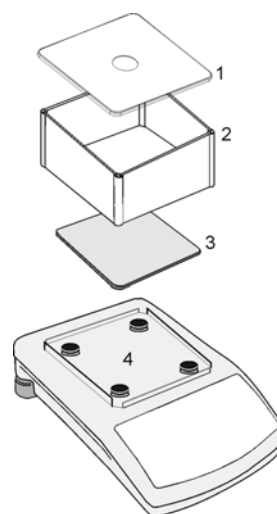

6.2.2 List of items supplied

Standard accessories:

- Balance
- Weighing plate
- Mains device (Power adaptor)
- Operating Instructions
- Draft shield (only for models up to d = 1mg)
- Protective working cover

6.3 Mains supply

Electric power supply is by means of the external mains supply circuit. The printed voltage level must comply with the local voltage.

Only use original KERN mains supply circuits. The use of other makes is subject to approval by Kern.

6.4 Connection of peripheral equipment

The balance must be disconnected from the mains before connecting or disconnecting additional equipment (printer, PC) to or from the data interface.

Only use KERN accessories and peripheral equipment with your balance. These have been ideally coordinated to your balance.

6.5 Initial start-up

In order to obtain exact results with the electronic balances, your balance must have reached the operating temperature (see warming up time chap. 1). During this warming up time, the balance must be connected to the power supply (mains, accumulator or battery).

For verified balances series PLJ...-3M there is warming up time, during which the display indicates **[burn - in]**.

The accuracy of the balance depends on the local acceleration of the fall.



Instructions in chapter Adjustment must be observed.

6.5.1 Power display

If this character [:] is visible, the balance is supplied with power via the mains power supply. Actuating the **ON/OFF** –button will switch the balance into weighing mode.

This way, the power display in the display overview is no longer visible.

6.5.2 Stability display

If the display shows the stability display [] the balance is in a stable status. If the status is instable the [] display disappears (see also chapter 8.2.1). Stable environment conditions may be reached by using a draft shield.

6.5.3 Balance zero-display

If the balance does not show exactly zero although the pan scale is unloaded, press the **TARE**-button and the balance will be reset to zero [→0←].

6.5.4 Auto-zero-function

In the menu you can turn on or off the auto-zero-function. To do so, proceed as follows:

- ⇒ Turn on balance using the **ON/OFF**-button
- ⇒ Press the **Tare**-button; the display shows horizontal lines
- ⇒ While this display shows, press the **CAL**-button, until **AUtO** is displayed
- ⇒ Press the **PRINT**-button; the display now shows the current menu item blinking
- ⇒ Use the **F**-button to choose between the following settings:
 - AUtO 0**: Auto-zero-function activated
(Display [ / →0←])
 - AUtO 1**: Auto-zero-function deactivated
- ⇒ Use the **PRINT**-button to confirm the selected setting

6.6 Adjustment

As the acceleration value due to gravity is not the same at every location on earth, each balance must be coordinated - in compliance with the underlying physical weighing principle - to the existing acceleration due to gravity at its place of location (only if the balance has not already been adjusted to the location in the factory). This adjustment process must be carried out for the first commissioning, after each change of location as well as in case of fluctuating environment temperature. It is also recommendable to adjust the balance periodically during weighing operation in order to obtain exact measured values.

6.6.1 Adjusting with internal weight (only PLJ/ALJ)

The installed adjusting weight allows checking and resetting the weighing accuracy at any time.

The automatic adjustment function is always active.

You can also start adjustment manually by pressing the **Cal**-button.

Automatic adjustment is started when the balance is

- cut off from power supply,
- when changing temperature
- after a time interval

Temperature / time controlled adjustment is taking place:

5 minutes before the start of automatic adjustment, this will be announced by a "° C", (change of temperature) or a "▶" (after a certain time interval ends) symbol on the display. The user must complete his/her weighing process within this time. After 5 minutes [CAL 30] appears on the display. This starts a "count down" of 30 seconds [CAL 30] → [CAL 0]. During these 30 seconds it is possible to cancel the adjustment by pressing the **TARE** key. This makes the balance return to weighing mode in order to e. g. complete an unfinished measurement.

6.6.2 Adjusting with external weight (only PLS/ALS)

Carry out adjustment with the recommended adjusting weight (see Chapter 1 „Technical Data“).

Procedure for adjustment:

Observe stable environment conditions. A warming-up time of ca. 2 hours for stabilisation is necessary.

- ⇒ Use the **ON/OFF**-button to turn on the balance.
- ⇒ Press **CAL**-button; the display shows **NO CAL**.
- ⇒ Wait until **LOAD** is displayed, then place adjusting weight (see Chapter 1 „Technical Data“) carefully in the centre of the weighing plate.
- ⇒ The display shows **CAL**, adjustment is started.
- ⇒ The display shows **UNLOAD**, adjustment is completed.
- ⇒ Remove adjusting weight, the balance will automatically return to weighing mode.

In case of an adjustment error or wrong adjusting weight **CAL Err** is displayed; repeat adjustment process

Keep test weight with the balance. Daily checking of the weighing accuracy is recommended for quality-relevant applications.

6.7 Verification

General:

According to the EU guideline 90/384/EEC balances must be verified officially if they are to be used as follows (legally regulated area):

- a) For commercial transactions if the price of goods is determined by weighing
- b) For the production of medicines in pharmacies as well as for analyses in the medical and pharmaceutical laboratory
- c) For official purposes
- d) For the production of finished packages

In case of doubt, please contact your local office of weights and measures.

Verification information

An EU qualification approval is available for those balances marked as appropriate for verification in the technical data. In the event that the balance is applied in an area subject to verification as described above, it must be officially verified and re-verified at regular intervals.

Re-verification of a balance is carried out in compliance with the respective legal provisions of the states. The term of verification validity for balances in Germany, for example, is normally 2 years.

The legal provisions of the country of use are to be observed.

After verification the balance is sealed at the marked positions.

Verification of the balance is invalid without the seal.

Position of the seal:

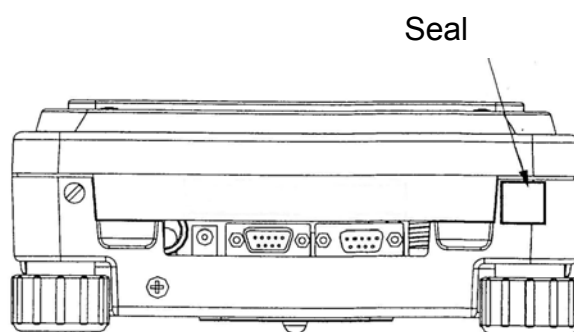

Balances with obligatory verification must be taken out of service if:

- **The weighing result of the balance is outside the maximum limits of operating errors.** Therefore load balance is regular intervals with known test weight (ca. 1/3 of the max. load) and compare with displayed value.
- **The date for subsequent or periodical verification has passed.**

6.8 Under floor weighing

Using under floor weighing allows weighing of objects that because of their size or shape cannot be placed on the pan scale.

Proceed as follows:

- Turn off balance.
- Open the closing lid at the bottom of the balance.
- **Carefully and completely** hook in the hook for under floor weighing.
- Place balance over an opening.
- Suspend the item to be weighed from the hook and carry out weighing.

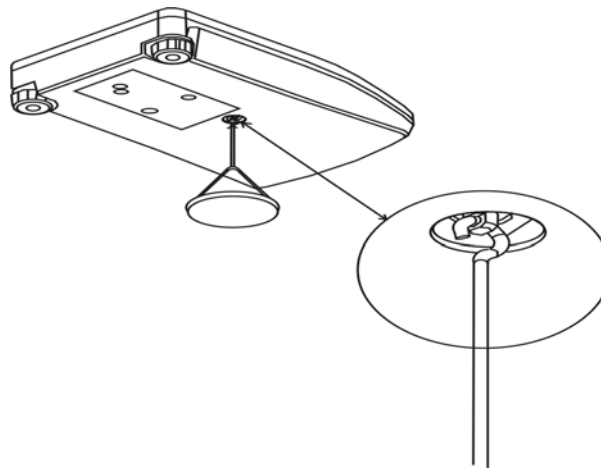

Fig. 1: Setting up balance for under floor weighing



CAUTION

- **Ensure that all suspended objects are stable enough to hold the desired items to be weighed securely (danger of breaking).**
- **Never suspend loads that exceed the stated maximum load (Max) (danger of breaking)**

Always ensure that underneath the load there are no living beings or objects that might be damaged.



NOTE

When the under floor weighing the opening in the bottom of the balance must be closed (protection against dust).

7 Operation

7.1 Operating elements

7.1.1 Rear illuminated Display

Contrasting display which can also be read in the dark.



To choose the backlight mode, please follow the below instruction for the setting:

Operation:	Display:
⇒ Use the ON/OFF -button to turn on the balance	
⇒ Press Tare -button	
⇒ While this display is on, press the CAL -button. The first function “ bl ” appears.	
⇒ Press the PRINT -key; display shows actual value for this function	
⇒ Use the F -key to choose between the following settings: 0 Backlight is turn off 1 Backlight is turn on	
⇒ Press key PRINT to confirm setting	

7.1.2 Keyboard:

Key	Function
ON/OFF	<ul style="list-style-type: none">• Turn on/off
PRINT	<ul style="list-style-type: none">• Printout of the weighed value on an external appliance (printer or PC)• Save settings
CAL	<ul style="list-style-type: none">• Adjusting function (manual)
F	<ul style="list-style-type: none">• Function key• Switching between weighing units
TARE/→0←	<ul style="list-style-type: none">• Taring• Set weight display at zero

7.2 Weighing

7.2.1 Simple weighing

Operation:	Display:
⇒ Use the ON/OFF -button to turn on the balance	
⇒ As soon as the weight display shows „ 0.000 “ your balance is ready for weighing	0,0000
⇒ Place items to be weighed on balance, the weighed value is displayed.	19.6879 g
⇒ Pressing the F -button you can switch to another weighing unit, e.g. ct (see Chapter 7.2.2)	98.4380 ct
⇒ To turn off the balance press the ON/OFF -button	

7.2.2 Weighing Units

Switching option for a weighing unit by multiple pressing of the **F**-button:

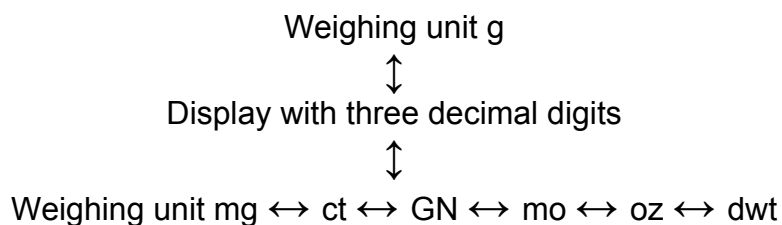

	Display	Conversion factor 1 g =
Gram	g	1.
Ounce	oz	0.035273962
Grain	GN	15.43235835
Pennyweight	dwt	0.643014931
Momme	mo	0.2667
Carat	ct	5

Different foreign weighing units are integrated in the various balance models. For details see Chapter 1 „Technical Data“.

Standard weighing unit:

Selected weighing unit remains when appliance is disconnected from power supply.

⇒ Actuate tare-key; the display shows horizontal lines; during this display actuate the **CAL**-key.



⇒ The first function “**AUTO**” appears.
Keep **F**-key pressed until “**St_uni**” appears

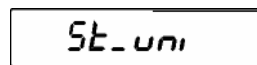

⇒ Select your weighing unit by actuating the **PRINT**-key several times

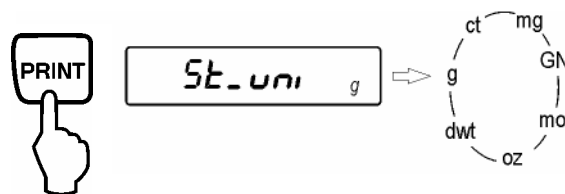

⇒ Confirm your selection with the **Tare**-key

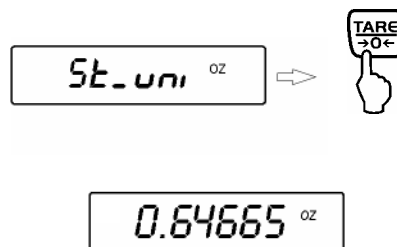

⇒ Disconnect balance from power supply and turn on again. Now your saved weighing unit is displayed – even after the appliance is disconnected from power supply again.

Notice:

Models that can be verified can only be switched from “g” to “ct”.

7.3 Taring

The dead weight of any type of weighing container can be tared out by pressing a button, so that subsequent weighing procedures show the net weight of the items to be weighed.

Operation:	Display:
⇒ Use the ON/OFF -button to turn on the balance	
⇒ As soon as the weight display shows „ 0.0000 “ your balance is ready for weighing	0.0000 g
⇒ Place items to be weighed on balance, the weighed value is displayed.	19.6879 g
⇒ Press the TARE -button to start the taring process. The weight of the container is now saved internally.	0.0000 g
⇒ Place the item to be weighed into the tare container. Now read the weight of the items to be weighed on the display.	53.2587 g

The taring process can be repeated any number of times, e.g. for several components for a mixture (add-on weighing).

The limit is reached when the whole weighing range is exhausted.

After removing the tare container the overall weight is displayed in the negative.

7.4 Adding of display values (only PLJ)

Any number of individual weighing procedures are automatically added to form a total sum, e.g. all individual weighing procedures of one batch.

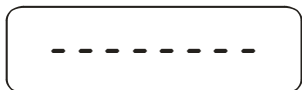
Operation:	Display:
⇒ Use the ON/OFF -button to turn on the balance	
⇒ Press Tare -button	

⇒ While this display is on, press the F -button	
⇒ Press PRINT -button, icon [▲] for sum function appears	
⇒ Put on weight A	
⇒ The displayed value is added to the memory by pressing the PRINT -button	
⇒ Press Tare -button	
⇒ Put on another weight B	
⇒ The displayed value is added to the memory by pressing the PRINT -button	
⇒ Press Tare -button	
⇒ Put on another weight C	
⇒ The displayed value is added to the memory by pressing the PRINT -button	
⇒ After completing the individual weighing procedures the total of all weighing procedures A+B+C is displayed when pressing the PRINT -button twice	
⇒ Remove weight, return to weighing mode by pressing the F key	

7.5 Parts counting

You are weighing e.g. 10 identical parts; i.e. the reference quantity is 10. The balance will automatically calculate the average weight per part. From now the pieces to be counted are displayed as number of parts. As a rule:

The higher the reference quantity the higher the counting accuracy.

Explanations for the balance settings:

The reference formation needs an exact determination of the weight value. The settings „Con 1 – 5“ (see chapter 8.2) influence this reference formation.

When using the counting function we recommend the setting: „Con 5“.

Operation:	Display:
⇒ Turn on balance using the ON/OFF -button	0,000
⇒ Press Tare -button	-- -- -- --
⇒ While this display is on, press the F -button until PIECES is displayed	PIECES
⇒ Press PRINT -button and reference quantity appears. By pressing the F -button, you can select 10, 20, 50 or FrEE (by choice).	10 ^{pcs}
⇒ Confirm entered reference quantity by pressing the PRINT -button. If you wish to select reference quantity by choice, proceed to the next step.	LoAD
⇒ Enter reference quantity by choice Use the ON/OFF -button to select the value you want to modify, use the F -button to increase the number (the respective active value is blinking) Confirm entered reference quantity by pressing the PRINT -button	00000 ^{pcs} 00017 ^{pcs} LoAD
⇒ Place as many parts on the weighing plate as required by the set reference quantity, confirm by pressing the PRINT -button	Proces ↓ 10 ^{pcs}

⇒ The balance is now in parts counting mode counting all the parts that are on the weighing plate (e.g. 7 parts)	7 pcs
⇒ To return to weighing mode press the Tare -button	-- -- -- --
⇒ While this display is on, press the F -button until PIECES is displayed	PIECES
⇒ Press Tare -button, balance is now in weighing mode	0,000 g

7.6 Percentage determination

Percentage determination allows the display of the weight in percent, in relation to a reference weight.

7.6.1 Determination of a reference weight by weighing

Operation:	Display:
⇒ Turn on balance using the ON/OFF -button	0,000
⇒ Press Tare -button	-- -- -- --
⇒ While this display is on, keep the F -button pressed until PErc A is displayed	PErc A
⇒ Press PRINT -button	LoAD
⇒ Put on reference weight, press the PRINT -button, the weight is stored as reference (100%).	ProcES ↓ 100.00 %
⇒ Now place items to test onto the weighing plate, the percentage in relation to the reference part is displayed.	70.37 %
⇒ To return to weighing mode press the Tare -button	-- -- -- --
⇒ While this display is on, press the F -button	
⇒ Press Tare -button, balance is now in weighing mode	0 g

7.6.2 Determination of a reference weight by numeric entry

Operation:	Display:
⇒ Turn on balance using the ON/OFF -button	0,000
⇒ Press Tare -button	-- -- -- --
⇒ While this display is on, keep the F -button pressed until PErc b is displayed	PErc b
⇒ Press PRINT -button	0000,0000 g
⇒ Enter reference weight (e.g. 90.33 g) Use the ON/OFF -button to select the value you want to modify, use the F -button to increase the number value (the respective active value is blinking)	0090,3300 g
⇒ Press PRINT -button, the weight is stored as reference (100%).	0.00 %
⇒ Now place items to test onto the weighing plate, the percentage in relation to the reference part is displayed.	70.37 %
⇒ To return to weighing mode press the Tare -button	-- -- -- --
⇒ While this display is on, press the F -button	
⇒ Press Tare -button, balance is now in weighing mode	0,000 g

8 Functions

8.1 Weighing functions

Menu selection:

- ⇒ Turn on balance using the **ON/OFF**-button
- ⇒ Press the **Tare**-button; the display shows horizontal lines
- ⇒ While this display is on, keep the **F**-button pressed until your desired selection is displayed

Function	Display F-button	Choice PRINT- button	Description of the selection options
Adding of displayed values (only PLJ, Chapter 7.4)	Add		
Parts counting (Chapter 7.5)	PIECES		
Percent-weighing	PErc A		Determination of a reference weight by weighing, (Chapter 7.6.1)
	PErc b		Determination of a reference weight by numeric entry, (Chapter 7.6.2)
Density determination for solid matters (see operating instructions density set)	- Co -	H2O	Measuring medium: Dest. water
		C2H5OH	Measuring medium: Alcohol 20°C
		AnothEr	Measuring medium: Liquid with known density
Density determination for liquids (see operating instructions density set)	- Li -		

8.2 General functions

Menu selection:

- ⇒ Turn on balance using the **ON/OFF**-button
- ⇒ Press the **Tare**-button; the display shows horizontal lines
- ⇒ While this display is on, press the **Cal**-button
- ⇒ Keep **F**-button pressed until the desired selection is displayed

Function	Display F-button	Selection PRINT-button ↓ F-button	Description of the selection options
Rear illuminated Display (see Chapter. 7.1.1)	bl	0	off
		1	on
Auto-zero-function (see Chapter 6.5.4)	AUTO	AUTO 0*	Auto-zero- function activated
		AUTO 1	Auto-zero- function deactivated
Setting the automatic adjustment function, only ALJ /PLJ6100-2 in non-verified setting (see Chapter 6.7.1)	Ac_t	Ac_t 0*	Automatic adjustment function activated
		Ac_t 1	Automatic adjustment function deactivated
	Ac_c	AC_c 0*	Automatic adjustment function activated
		AC_c 1	Automatic adjustment function deactivated
Data output (only ALJ / PLJ6100-2 in non-verified setting)	Pd_d	Pd_d 0*	Last digit is not printed
		Pd_d 1	Last digit is printed
Vibration filter	Con	Con 1	Sensitive and fast (very quiet set-up location) ↓ Robust but slow (very busy set-up location)
		Con 2	
		Con 3*	
		Con 4	
		Con 5°	
Forming of an average value (Animal weighing program)	AuE	AuE 1	Fastest display
		AuE 2*	↓ Slowest display
		AuE 3	
Display speed	FIL	FIL 0*	Setting for dosing deactivated
		FIL 1	Setting for dosing activated
Standard weighing unit	St_uni		see Chapter 7.2.2

* = Factory setting

° = Recommended counter setting

8.3 Parameter for the serial interface

Menu selection:

- ⇒ Turn on balance using the **ON/OFF**-button
- ⇒ Press the **Tare**-button; the display shows horizontal lines
- ⇒ While this display is on, press the **PRINT** -button
- ⇒ Keep **F**-button pressed until the desired selection is displayed

Function	Display F-button	Choice PRINT- button	Description of the selection options
Baud rate	bod	bod 1	300 bps
		bod 2	600 bps
		bod 3	1200 bps
		bod 4	2400 bps
		bod 5*	4800 bps
		bod 6	9600 bps
Output conditions at the interface	StAb (only ALJ 120/220 in non- verified setting)	StAb 0*	Output for stable Weighing value
		StAb 1	Output also for instable weighing value
	cont	cont 0*	Consecutive serial output deactivated, output only when button is pressed
		cont 1	Consecutive serial output
	dAtE	dAtE 0*	Printout of the weighing values without placeholder for date/time
		dAtE 1	Printout of the weighing values with placeholder for date/time
	Repl (Condition: cont 0)	Repl 0	Issue takes place after pressing the PRINT key.
		Repl 1	Automatic issue of first stable weighing value Sequence of operations: 1. Tare 2. Place weight, issue of first stable weighing value 3. No next issue until weight is removed Condition: Display +/- 50 display steps from zero 4. Place next weight

* = Factory setting

- ⇒ Confirm setting by pressing the **PRINT**-button

9 Data output RS 232 C

9.1 Technical Data

- 8-bit ASCII code
- 8 Data bits, 1 stop bit, no parity bit
- Baud rate selectable for 300, 600, 1200, 2400, **4800** and 9600 Baud
- Miniature plug necessary (9 pol D-Sub)
- For operation with interface faultless operation is ensured only with the respective KERN- interface cable (max. 2m)

9.2 Pin allocation of the balance exit plug (front view)

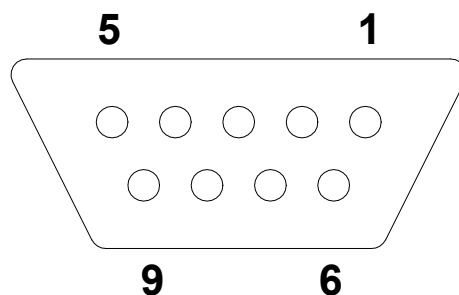

Pin 2: Receive data
 Pin 3: Transmit data
 Pin 5: Signal ground

9.3 Interface cables

⇒ Balance printer

3 (TxD)	1 (RxD)
5 (GND)	3 (GND)
7 - 8 clench	

⇒ Balance - PC 9-pole

2 (RxD)	3 (TxD)
3 (TxD)	2 (RxD)
5 (GND)	5 (GND)
4 - 6 clench	4 - 6 clench
7 - 8 clench	7 - 8 clench

⇒ Balance - PC 25-pole

2 (RxD)	3 (TxD)
3 (TxD)	7 (GND)
5 (GND)	4 - 5 clench
7 - 8 clench	6 - 20 clench
2 (RxD)	

9.4 Description of the data transfer (data format)

9.4.1 Output when pressing the PRINT-button

1	2	3	4	5	6	7	8	9	10	11	12	13	14	15	16
+	B	B	B	B	0	.	0	0	0	B	B	g	B	C _R	L _F

1	2	3	4	5	6	7	8	9	10	11	12	13	14	15	16
+	B	B	B	2	0	.	0	1	1	B	B	g	B	C _R	L _F

9.4.2 Remote commands

Taring:

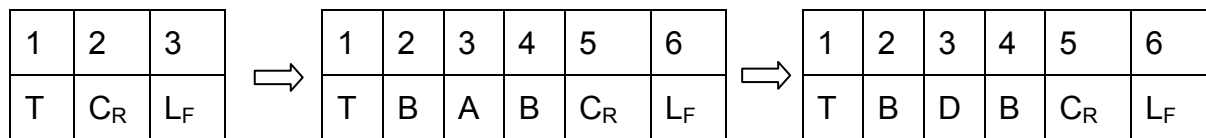

Stable/instable values:

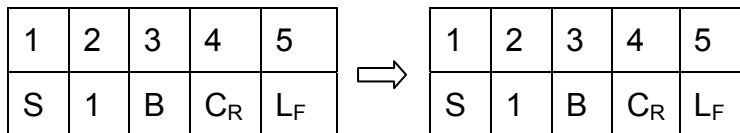

9.4.3 Output format

Stable values:

1	2	3
S	C _R	L _F

1	2	3	4	5	6
S	B	A	B	C _R	L _F

Display 0.000 g

1	2	3	4	5	6	7	8	9	10	11	12	13	14	15	16	17	18	19	20
S	B	B	B	+	B	B	B	B	0	.	0	0	0	B	B	g	B	C _R	L _F

Display 45,288 g

1	2	3	4	5	6	7	8	9	10	11	12	13	14	15	16	17	18	19	20
S	B	B	B	+	B	B	B	4	5	.	2	8	8	B	B	g	B	C _R	L _F

Instable values:

1	2	3	4
S	I	C _R	L _F

Display 0.000 g

1	2	3	4	5	6	7	8	9	10	11	12	13	14	15	16	17	18	19	20	21
S	I	B	B	B	+	B	B	B	B	0	.	0	0	0	B	B	g	B	C _R	L _F

Display 45,288 g

1	2	3	4	5	6	7	8	9	10	11	12	13	14	15	16	17	18	19	20	21
S	I	B	B	B	+	B	B	B	4	5	.	2	8	8	B	B	g	B	C _R	L _F

SYMBOLS:

B	Space
0	Values for weight
.	Decimal point, depending on weighing value
g	Edit weighing unit
C _R	Carriage return character (Carriage Return)
L _F	Line feed character (Line Feed)
S/I	Stable/instable weighing value
T	Taring

10 Maintenance, upkeep, disposal

10.1 Cleaning

Please disconnect the device from the operating voltage before cleaning.

Only use a cloth dampened with mild suds and not aggressive cleaning agents (solvents or similar). Please ensure that fluids are not able to get into the device and rub off using a clean, soft cloth.

Loose sample residue/powder can be removed carefully using a brush or hand vacuum cleaner.

Remove any spilt material to be weighed immediately.

10.2 Maintenance, upkeep

The device may only be opened by trained service engineers authorised by KERN. Disconnect from the mains supply before opening.

10.3 Disposal

The operating company shall dispose of the packaging and the device in compliance with the valid national or regional law of the operating location.

11 Troubleshooting

The balance should be switched off for a short time following an interruption in the programme sequence and disconnected from the mains supply. It is then necessary to repeat the weighing process from the beginning.

Help:

Fault

Possible cause

Weight display is not illuminated.

- *The balance is not switched on.*
- *The mains supply connection has been interrupted (mains cable not plugged in/faulty).*
- *Power supply interrupted.*
- *Batteries are inserted incorrectly or empty*
- *There are no batteries inserted.*

The weight display changes continually

- *Draught/air movement*
- *Table/floor vibrations*
- *The weighing plate is in contact with foreign matter.*
- *Electromagnetic fields / static charging (choose different location/switch off interfering device if possible)*

The weighing result is obviously wrong

- *The display of the balance is not at zero*
- *Adjustment is no longer correct.*
- *Great fluctuations in temperature.*
- *Electromagnetic fields / static charging (choose different location/switch off interfering device if possible)*

Error messages

Zero

FuLL-1

FuLL-2

Err-5

Err-3

CAL- Err

- *Weight too small*
- *A/D transducer range exceeded*
- *Maximum load of the balance exceeded*
- *Error of the temperature sensor, turn balance on and off*
- *Error for internal adjustment*
- *Adjustment error or wrong test weight, Repeat adjustment process*

Switch the balance off if other error messages should appear and then switch on again. If error message persists, inform manufacturer.