



KERN & Sohn GmbH

Ziegelei 1
D-72336 Balingen
E-Mail: info@kern-sohn.com

Tel: +49-[0]7433- 9933-0
Fax: +49-[0]7433-9933-149
Internet: www.kern-sohn.com

Operating Manual Compact balance

KERN FWN

Version 1.1
04/2007
GB



FWN-BA-e-0711



KERN FWN

Version 1.1 04/2007

Operating Manual

Compact balance

Table of Contents

1	Technical data	3
2	Declarations of conformity	5
2.1	Electronic Compact Balance (verifiable)	6
3	Appliance overview	7
4	Description of parts	8
5	Basic Information (General)	9
5.1	Proper use	9
5.2	Improper Use	9
5.3	Warranty	9
5.4	Monitoring of Test Resources	10
6	Basic Safety Precautions	10
6.1	Pay attention to the instructions in the Operation Manual	10
6.2	Personnel training	10
7	Transport and storage	10
7.1	Testing upon acceptance	10
7.2	Packaging	10
8	Unpacking, Setup and Commissioning	11
8.1	Installation Site, Location of Use	11
8.2	Unpacking	12
8.3	Setup	12
8.3.1	Scope of delivery	12
8.4	Battery operation	12
8.5	Mains adapter (optional)	13
8.6	Initial Commissioning	13
8.7	Adjustment	14
8.7.1	Procedure when adjusting	14
8.8	Verification	15
8.9	Adjustment switch and seal	16
9	Weighing	17
9.1	Simple weighing	17
9.2	Taring	17
10	Service, maintenance, disposal	18
10.1	Cleaning	18
10.2	Service, maintenance	18
10.3	Disposal	18
11	Instant help	19

1 Technical data

(non verifiable models)

KERN	FWN 300-1IP	FWN 1K0.5IP
<i>Readability (d)</i>	0.1 g	0.5 g
<i>Weighing range (max)</i>	300 g	1,000 g
<i>Reproducibility</i>	0.1 g	0.5 g
<i>Linearity</i>	0.2 g	1 g
<i>Recommended adjusting weight (not supplied) (class)</i>	200 g + 100g (M2)	1000 g (M3)
<i>Stabilization time (typical)</i>	2 sec.	
<i>Operating temperature</i>	-10° C + 40° C	
<i>Warming up time (operating temperature)</i>	10 min.	
<i>Humidity of air</i>	10 % - 95 % (not condensing)	
<i>Weighing Units</i>	g	
<i>Housing (B x D x H) (mm)</i>	170 x 220 x 63	170 x 220 x 63
<i>Weighing plate, stainless steel (mm)</i>	128 x 128	
<i>Weight kg (net)</i>	0.9	
<i>Battery operation</i>	6 x AA 1.5 V	
<i>IP protection type (only in battery operation)</i>	IP65	

Verifiable model

KERN	FWN 3K1IPM
<i>Readability (d)</i>	1 g
<i>Weighing range (max)</i>	3,000 g
<i>Minimum load (Min)</i>	20 g
<i>Verification value (e)</i>	1 g
<i>Verification class</i>	III
<i>Reproducibility</i>	1 g
<i>Linearity</i>	2 g
<i>Recommended adjusting weight (not supplied) (class)</i>	2000 g + 1000 g (M2)
<i>Stabilization time (typical)</i>	2 sec.
<i>Operating temperature</i>	-10° C + 40° C
<i>Warm-up time</i>	10 min.
<i>Humidity of air</i>	10 % - 95 % (not condensing)
<i>Weighing Units</i>	g
<i>Housing (B x D x H) (mm)</i>	174 x 220 x 63
<i>Weighing plate, stainless steel (mm)</i>	174 x 137
<i>Weight kg (net)</i>	1
<i>Battery operation</i>	6 x AA 1.5 V
<i>IP protection type (only in battery operation)</i>	IP65

2 Declarations of conformity

Declaration of conformity

Declaration of conformity for apparatus with CE mark
Konformitätserklärung für Geräte mit CE-Zeichen
Déclaration de conformité pour appareils portant la marque CE
Declaración de conformidad para aparatos con marca CE
Dichiarazione di conformità per apparecchi contrassegnati con la marcatura CE

- English** We hereby declare that the product to which this declaration refers conforms to the following standards.
- Deutsch** Wir erklären hiermit, daß das Produkt, auf das sich diese Erklärung bezieht, mit den nachstehenden Normen übereinstimmt.
- Français** Nous déclarons avec cela responsabilité que le produit, auquel se rapporte la présente déclaration, est conforme aux normes citées ci-après.
- Español** Manifestamos en la presente que el producto al que se refiere esta declaración está de acuerdo con las normas siguientes
- Italiano** Dichiariamo con ciò che il prodotto al quale la presente dichiarazione si riferisce è conforme alle norme di seguito citate.

Electronic Scale: KERN FWN

Mark applied	EU Directive	Standards
	89/336/EEC EMC	EN 61326
	73/23/EEC LVD	EN 60950

Date: 10.01.2007

Signature:



Gottl. KERN & Sohn GmbH
Management

Gottl. KERN & Sohn GmbH, Ziegelei 1, D-72336 Balingen, Tel. +49-[0]7433/9933-0, Fax +49-[0]7433/9933-149

2.1 Electronic Compact Balance (verifiable)

Declarations of conformity

Declaration of conformity for apparatus with CE mark
Konformitätserklärung für Geräte mit CE-Zeichen
Déclaration de conformité pour appareils portant la marque CE
Declaración de conformidad para aparatos con marca CE
Dichiarazione di conformità per apparecchi contrassegnati con la marcatura CE

- English** We hereby declare that the product to which this declaration refers conforms to the following standards.
This declaration is only valid with the certificate of conformity by a notified body.
- Deutsch** Wir erklären hiermit, daß das Produkt, auf das sich diese Erklärung bezieht, mit den nachstehenden Normen übereinstimmt.
Diese Erklärung gilt nur in Verbindung mit der Konformitätsbescheinigung einer benannten Stelle.
- Français** Nous déclarons avec cela responsabilité que le produit, auquel se rapporte la présente déclaration, est conforme aux normes citées ci-après.
Cette déclaration est valide seulement avec un certificat de conformité d'un organisme notifié.
- Español** Manifestamos en la presente que el producto al que se refiere esta declaración está de acuerdo con las normas siguientes
Esta declaración solo será válida acompañada del certificado de conformidad de conformidad de la parte nominal.
- Italiano** Dichiariamo con ciò che il prodotto al quale la presente dichiarazione si riferisce è conforme alle norme di seguito citate.
Questa dichiarazione sarà valida solo se accompagnata dal certificato di conformità della parte nominale.

Electronic Scale: KERN FWN

Model:	FWN 3K1IPM
--------	------------

EU Directive	Standards	EC-type-approval certificate no.	Issued by
90/384/EEC	EN 45501	T7090	NMI

Date: 10.01.2007

Signature:

Gottl. KERN & Sohn GmbH
Management

Gottl. KERN & Sohn GmbH, Ziegelei 1, D-72336 Balingen, Tel. +49-07433/9933-0, Fax +49-074433/9933-149

3 Appliance overview

Model *FWN 3K1IPM* (verifiable)



Models *FWN 300-1IP*, *FWN 1K0.5IP* (not verifiable)



4 Description of parts

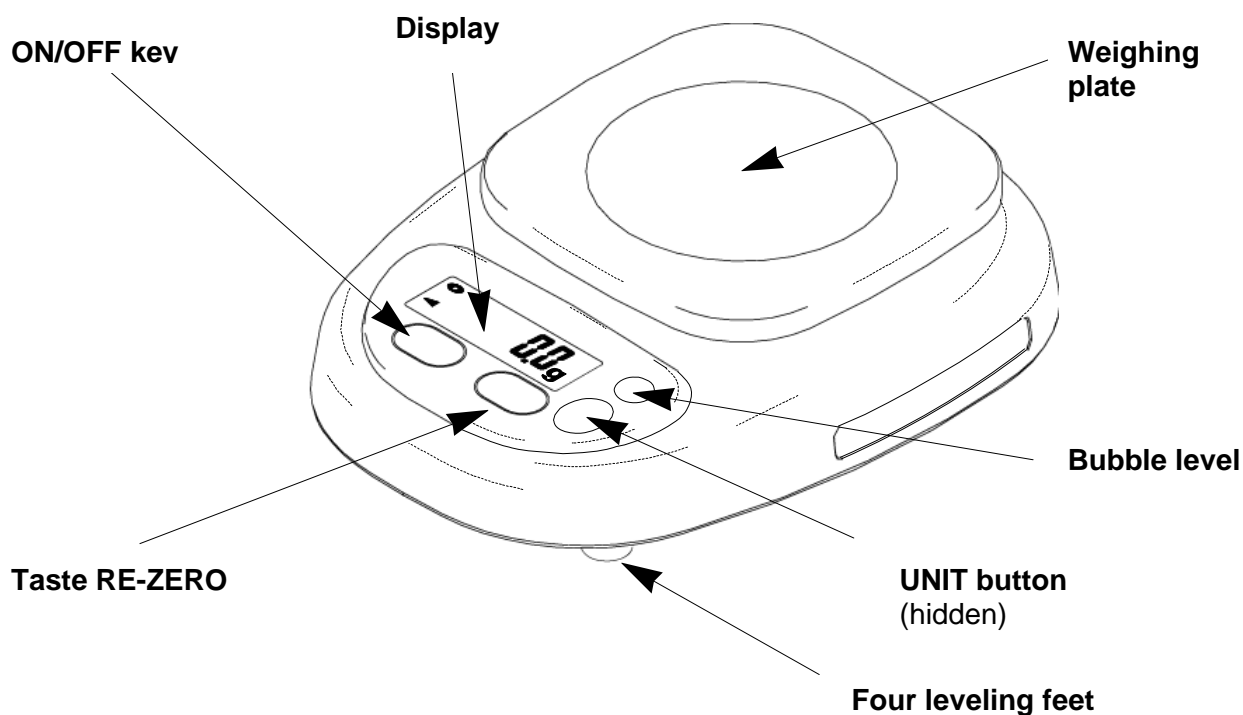

Models *FWN 300-1IP*, *FWN 1K0.5IP*

STABLE display
Indicates that the weighed value is stable.

ZERO display
Indicates when the balance is stable.

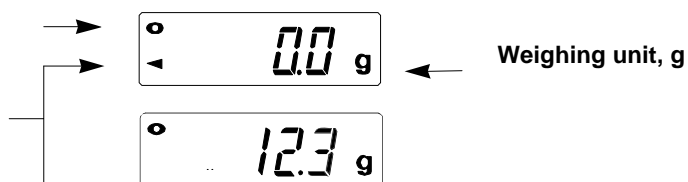

Model *FWN 3K1IPM*

NET display
Shows when the net weight appears. (tara function is used)



5 Basic Information (General)

5.1 Proper use

The balance you purchased is intended to determine the weighing value of material to be weighed. It is intended to be used as a “non-automatic” balance, i.e. the material to be weighed is manually and carefully placed in the centre of the weighing plate. As soon as a stable weighing value is reached the weighing value can be read.

5.2 Improper Use

Do not use balance for dynamic weighings. In the event that small quantities are removed or added to the material to be weighed, incorrect weighing results can be displayed due to the “stability compensation” in the balance. (Example: Slowly draining fluids from a container on the balance.)

Do not leave permanent load on the weighing plate. This may damage the measuring system.

Impacts and overloading exceeding the stated maximum load (max) of the balance, minus a possibly existing tare load, must be strictly avoided. Balance may be damaged by this.

Never operate balance in explosive environment. The serial version is not explosion protected.

The structure of the balance may not be modified. This may lead to incorrect weighing results, safety-related faults and destruction of the balance.

The balance may only be used according to the described conditions. Other areas of use must be released by KERN in writing.

5.3 Warranty

Warranty claims shall be voided in case

- Our conditions in the operation manual are ignored
- The appliance is used outside the described uses
- The appliance is modified or opened
- Mechanical damage and damage caused by media, liquids
- Natural wear and tear
- The appliance is improperly set up or incorrectly electrically connected
- The measuring system is overloaded

5.4 Monitoring of Test Resources

In the framework of quality assurance the measuring-related properties of the balance and, if applicable, the testing weight, must be checked regularly. The responsible user must define a suitable interval as well as type and scope of this test. Information is available on KERN's home page (www.kern-sohn.com) with regard to the monitoring of balance test substances and the test weights required for this. In KERN's accredited DKD calibration laboratory test weights and balances may be calibrated (return to the national standard) fast and at moderate cost.

6 Basic Safety Precautions

6.1 Pay attention to the instructions in the Operation Manual

Carefully read this operation manual before setup and commissioning, even if you are already familiar with KERN balances.

6.2 Personnel training

The appliance may only be operated and maintained by trained personnel.

7 Transport and storage

7.1 Testing upon acceptance

When receiving the appliance, please check packaging immediately, and the appliance itself when unpacking for possible visible damage.

7.2 Packaging

Keep all parts of the original packaging in case you need to return the appliance. Only use original packaging for returning.

Before sending, disconnect all connected cables and loose/movable parts.

Secure all parts, e.g. weighing plate, mains adapter etc., to prevent slipping and damage.

8 Unpacking, Setup and Commissioning

8.1 Installation Site, Location of Use

The balances are designed in a way that reliable weighing results are achieved in common conditions of use.

You will work accurately and fast, if you select the right location for your balance.

Therefore, observe the following for the installation site:

- Place the balance on a firm, level surface;
- Avoid extreme heat as well as temperature fluctuation caused by installing next to a radiator or in the direct sunlight;
- Protect the balance against direct draughts due to open windows and doors;
- Avoid jarring during weighing;
- Protect the balance against high humidity, vapours and dust;
- Do not expose the device to extreme dampness for longer periods of time. Non-permitted condensation (condensation of air humidity on the appliance) may occur if a cold appliance is taken to a considerably warmer environment. In this case, acclimatize the disconnected appliance for ca. 2 hours at room temperature.
- Avoid static charging of the material to be weighed, weighing container and windshield.

Major display deviations (incorrect weighing results) may be experienced should electromagnetic fields (e.g. due to mobile phones or radio equipment), static electricity accumulations or instable power supply occur. Change location or remove source of interference.

Special protection against moisture:

The FWN in battery operation fulfills the requirements of the **DIN EN 60529** for the **protection type IP65**.

The FWN is suitable for a short-time contact with liquids. For cleaning use a wet cloth. The FWN is sealed against dust in battery operation.

8.2 Unpacking

Carefully remove the balance from the packaging, remove plastic cover and setup balance at the intended workstation.

8.3 Setup

Level balance with foot screws until the air bubble of the water balance is in the prescribed circle.

Information: The non verifiable models bear the air bubble level under the weighing plate.

8.3.1 Scope of delivery

Serial accessories:

KERN FWN

- Balance
- Weighing plate
- Batteries (6 x AA 1.5 V)
- Operating Manual

8.4 Battery operation

When changing the batteries do not press too heavily on the weighing plate. An excessive pressure can damage the balance. Remove the battery cover and insert six batteries (6 x AA 1.5 V) in the battery compartment, take special care of the polarity plus and minus.

In order to save the battery, the balance switches automatically off after 5 minutes without weighing.

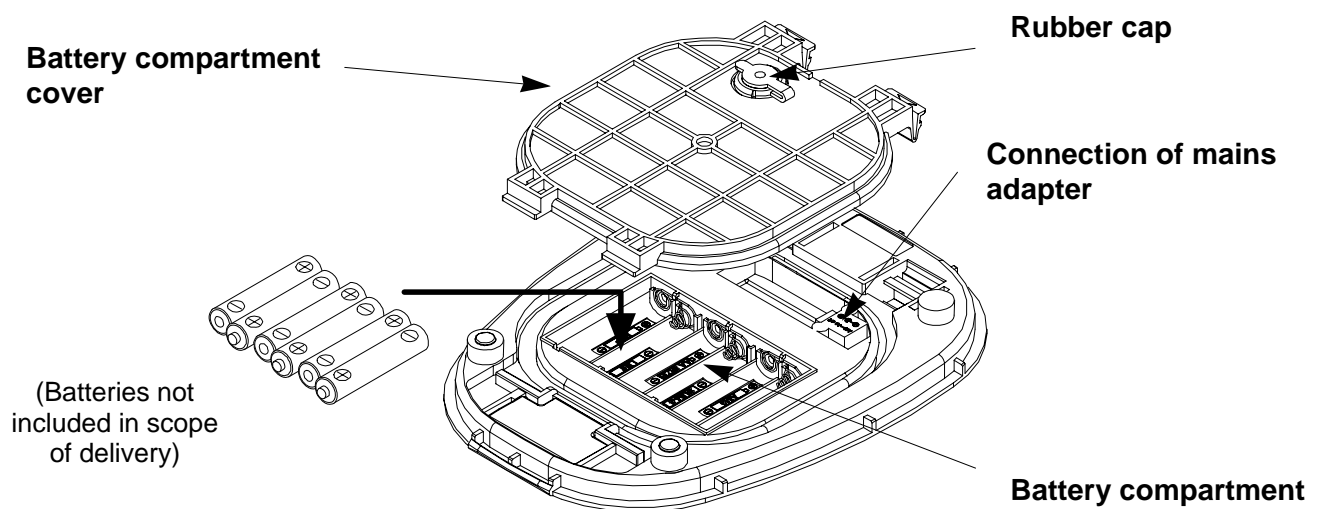

8.5 Mains adapter (optional)

Power is supplied via the external mains adapter.

The stated voltage value of the mains adapter must be the same as the local voltage. Only use original KERN mains adapter. Using other makes requires consent by KERN.

Caution

When using a mains adapter, the balance does not more fulfill the requirements according to IP65.

Power is supplied via the external mains adapter. The stated voltage value must be the same as the local voltage.

Only use original KERN mains adapters. Using other makes requires consent by KERN.

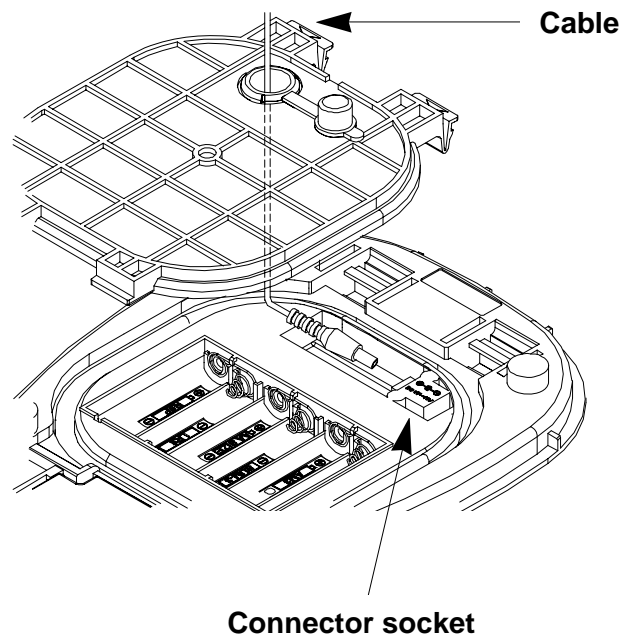

8.6 Initial Commissioning

In order to obtain exact results with the electronic balances, your balance must have reached the operating temperature (see warming up time chap. 1). During this warming up time the balance must be connected to the power supply (mains, accumulator or battery).

The accuracy of the balance depends on the local acceleration of gravity. Strictly observe hints in chapter Adjustment.

8.7 Adjustment

As the acceleration value due to gravity is not the same at every location on earth, each balance must be coordinated - in compliance with the underlying physical weighing principle - to the existing acceleration due to gravity at its place of location (only if the balance has not already been adjusted to the location in the factory). This adjustment process must be carried out during the initial start-up, after change in location and variation of surrounding temperature. To receive accurate measuring values it is also recommended to adjust the balance periodically in weighing operation.

The adjustment should be made with the recommended adjustment weight (see chap. 1 "Technical data"). Adjustment is also possible with the weights of other nominal values (see following table), but not the optimum for measuring technique.

Model	Recommended Adjustment weight	Other measurement-technically not optimal nominal values for adjustment
<i>FWN 300-1IP</i>	200 g + 100 g (M2)	200 g
<i>FWN 1K0.5IP</i>	1000 g (M3)	500 g
<i>FWN 3K1IPM</i>	2000 g + 1000 g (M2)	2000 g

Info about adjustment weights can be found on the Internet at: <http://www.kern-sohn.com>

8.7.1 Procedure when adjusting

Check that the surrounding conditions are stable.

A short warm-up time (see chap. 1) is recommended for stabilisation.

⇒ **Model FWN 3K1IPM (verifiable)**

Attention:

In the verified balances the adjustment is not possible (see chapter 8.9).

- Turn on balance by pressing the [ON/OFF] key
- Press adjustment switch (see chapter 8.9). **CAL** is displayed.
- Press the [TARE] button. **CAL 0** is displayed..
- Wait for the stabilisation display and press then the [TARE] button. **CAL F** is displayed.
- For an exact adjustment put the weight in the center of the weighing plate. Wait for the stabilisation display and press then the [TARE] button.
- The display shows **END**. Remove adjustment weight and the balance returns automatically into the weighing mode.

⇒ **Model FWN 300-1IP, FWN 1K0.5IP (not verifiable)**

- Press the [ON/OFF] key in order to switch off the power supply.
- Press as well the [TARE] button and the [UNITS] button and press at the same time the [ON/OFF] key. **CAL** is displayed.

Position of the UNITS key to call-up the adjustment function (not visible)

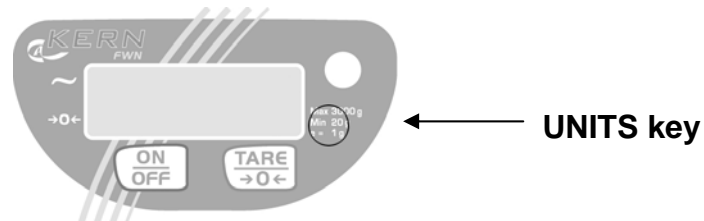

- Press the [TARE] button. **CAL 0** is displayed.
- Wait for the stabilisation display and press then the [TARE] button. **CAL F** is displayed.
- For an exact calibration put the weight in the center of the weighing plate. Wait for the stabilisation display and press then the [TARE] button.
- The display shows **END**. Remove adjustment weight and the balance returns automatically into the weighing mode.

8.8 Verification

General introduction:

According to EU directive 90/384/EEC balances must be officially verified if they are used as follows (legally controlled area):

- a) For commercial transactions if the price of goods is determined by weighing.
- b) For the production of medicines in pharmacies as well as for analyses in the medical and pharmaceutical laboratory.
- c) For official purposes
- d) For manufacturing final packages

In cases of doubt, please contact your local trade in standard.

Verification instructions

An EU type approval exists for balances described in their technical data as verifiable. If a balance is used where obligation to verify exists as described above, it must officially verified and re-verified in regular intervals.

Re-verification of a balance is carried out according to the respective national regulations. The validity for verification of balances in Germany is e.g. 2 years.

The legal regulation of the country where the balance is used must be observed!

8.9 Adjustment switch and seal

After verification the balance is sealed at the indicated positions.

Verification of the balance is invalid without the "seal".

Position of the seal and the adjustment switch:

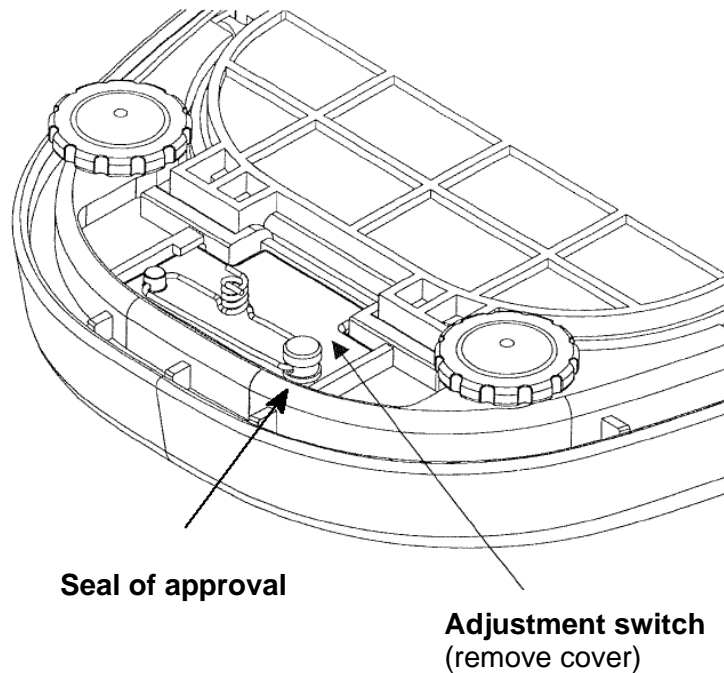

Balances with obligation to verify must be taken out of operation if:

- **The weighing result of the balance is outside the error limit.** Therefore, in regular intervals load balance with known test weight (ca. 1/3 of the max. load) and compare with displayed value.
- **The reverification deadline has been exceeded.**

.

9 Weighing

Take care of the automatic switch-off function. When this equipment is switched ON and the stabilisation display is active, after approx. 5 minutes the automatic switch-off function will be activated. In order to deactivate this function, press [ON/OFF] and [TARE] at the same time. **P-XX** is displayed, and the balance returns to the weighing mode.

9.1 Simple weighing

- Turn on balance by pressing the [ON/OFF] key
- Your balance is ready to weigh as soon as the "**0.000**" display appears.
- Put on items to be weighed, weighed value is displayed.
- To turn off the balance press the ON/OFF key

9.2 Taring

The dead weight of any weighing container may be tared away by pressing a button, so that the following weighings show the net weight of the goods to be weighed.

- Turn on balance by pressing the [ON/OFF] key
- Your balance is ready to weigh as soon as the "**0.000**" display appears.
- Put on container, weighed value is displayed.
- To start the taring process press the **TARE** key. The weight of the container is now saved internally.
- Place the goods to be weighed into the tare container.
Read the weight of the goods on the display.

The taring process can be repeated any number of times, e.g. when adding several components for a mixture (adding).

The limit is reached when the whole weighing range is exhausted.

After removing the taring container the total weight is displayed as negative display.

10 Service, maintenance, disposal

10.1 Cleaning

Before cleaning, please disconnect the appliance from the operating voltage.

Please do not use aggressive cleaning agents (solvents or similar agents), but a cloth dampened with mild soap suds. Ensure that no liquid penetrates into the device and wipe with a dry soft cloth.

Loose residue sample/powder can be removed carefully with a brush or manual vacuum cleaner.

Note for equipments with protection type as per DIN EN 60529(IPxx) see chapter 7.1

Spilled weighing goods must be removed immediately.

10.2 Service, maintenance

The appliance may only be opened by trained service technicians who are authorized by KERN.

Before opening, disconnect from power supply.

10.3 Disposal

Disposal of packaging and appliance must be carried out by operator according to valid national or regional law of the location where the appliance is used.

11 Instant help

In case of an error in the program process, briefly turn off the balance and disconnect from power supply. The weighing process must then be restarted from the beginning.

Help:

Fault

Possible cause

- | | |
|-----------------------------------------------------|------------------------------------------------------------------------------------------------------------------------------------------------------------------------------------------------------------------------------------------------------------------------------------------------------------------------------------------|
| <i>The displayed weight does not glow.</i> | <ul style="list-style-type: none">• <i>The balance is not switched on.</i>• <i>The mains supply connection has been interrupted (mains cable not plugged in/faulty).</i>• <i>Power supply interrupted.</i>• <i>The batteries are empty</i> |
| <i>The displayed weight is permanently changing</i> | <ul style="list-style-type: none">• <i>Draught/air movement</i>• <i>Table/floor vibrations</i>• <i>The weighing plate is in contact with foreign matter.</i>• <i>Electromagnetic fields / static charging (choose different location/switch off interfering device if possible)</i> |
| <i>The weighing value is obviously wrong</i> | <ul style="list-style-type: none">• <i>The display of the balance is not at zero</i>• <i>Adjustment is no longer correct.</i>• <i>Great fluctuations in temperature.</i>• <i>Electromagnetic fields / static charging (choose different location/switch off interfering device if possible)</i> |

Should other error messages occur, switch balance off and then on again. If the error message remains inform manufacturer.