

Instruction Manual

FT 1K

Thank you for buying a SAUTER force gauge. We hope you are pleased with your high quality force gauge with its big functional range. If you have any queries, wishes or helpful suggestions, do not hesitate to call our service number.

„Sensor Outside“ means the cell is outside the body.

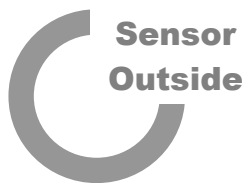

1. Included in Delivery

- SAUTER FT
- Carrying Case
- Standard Attachments

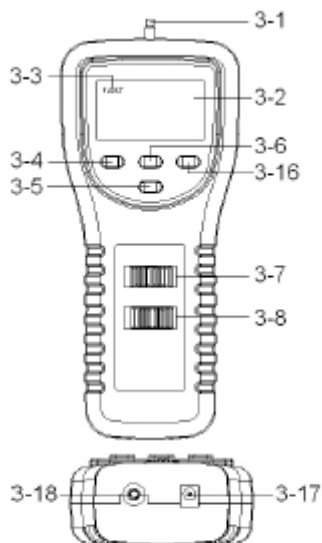

- 3.1. Universal Sensing Head
- 3.2. LCD Display
- 3.3. FAST Indicator
- 3.4. FAST / SLOW Button
- 3.5. LCD Reverse Display Button
- 3.6. Zero Button
- 3.7. Unit switch (N, g, oz)
- 3.8. Power Off/On/Peak Hold
- 3.9. Mounting holes/fixing Screws
- 3.10. Battery Cover/ Compartment
- 3.11. – 3.15. Standard Attachments
- 3.16. LCD Backlight Button
- 3.17. 9V DC Power Adapter Input Socket
- 3.18. RS 232 Output terminal

2. Warning

2.1 Intended use

The instrument you have acquired serves to determine the measuring value of the material to be measured. It is intended to be used as a “non-automatic” instrument, i.e. the material to be measured is manually and carefully attached at the instrument. The measuring value can be read off after a stable measuring value has been obtained.

2.2 Inappropriate use

Do not use the instrument for dynamic measuring. In the event that small quantities are removed or added to the material to be

measured, incorrect measuring results can be displayed due to the “stability compensation” in the instrument.

(Example: Slow draining

off of liquid from a container suspended from the instrument). Do not attach a continuous load. This can damage the measuring

unit as well as the parts, relevant to safety.

Prevent jolts, torsion and oscillation (e.g. by appending slopingly) of all kinds. Be sure to prevent overloading the instrument in excess of the stated maximum load (max.), minus any tare weight that may possibly exist. This could damage the instrument (risk of breakage).

Important:

- Always make sure that there are no people or materials below the load that could be injured or damaged!
- The instrument is not suitable for measuring people. Do not use as baby scales!
- The instrument does not comply with the medical product law (MPG).

Never operate the instrument in hazardous locations. The series design is not explosion-proof. Structural alterations may not be

made to the instrument. This can lead to incorrect measuring results, faults concerning safety regulations as well as to destruction

of the instrument. The instrument may only be used in compliance with the described guidelines. Varying areas of application/

planned use must be approved by SAUTER in writing.

2.3 Guarantee

The guarantee is not valid following

- non-observation of our guidelines in the operating instructions

- use outside the described applications

- alteration to or opening of the device

- mechanical damage and damage caused by media, liquids

- natural wear and tear

- inappropriate erection or electric installation

- overloading of the measuring equipment

2.4 Monitoring the test substances

Instruction Manual

FT 1K

The metrology features of the instrument and any possible available adjusting weight must be checked at regular intervals within the scope of quality assurance. For this purpose, the answerable user must define a suitable interval as well as the nature and scope of this check. Information is available on the home page (www.KERN-sohn.com) with regard to the monitoring of instrument test substances and the test weights required for this. Test weights and instruments can be adjusted quickly and at a reasonable price in KERN's accredited DKD calibration laboratory (return to national normal).

3. Fundamental safety information

Do not use the hanging instrument to transport loads. Prevent jolts, torsion and oscillation (e.g. by appending slopingly) of all kinds. Never use the hanging instrument over the maximum permitted weight (!!Danger of breaking!!). Always make sure that there are no living beings or materials below the load that could be injured or damaged. The hanging electronic instruments from the SAUTER instrument are only suitable for hand-held use or use in a test stand. They are not suitable for hanging from a mechanical hook, e.g. a crane hook.

3.1 Observe the information in the operating instructions
 Please read the operating instructions carefully before erecting

and commissioning, even if you already have experience with SAUTER instruments.

3.2 Staff training

The device may only be operated and looked after by trained members of staff.

4. Transport and storage

4.1 Acceptance check

Please check the packaging immediately upon delivery and the device during unpacking for any visible signs of external damage.

4.2 Packaging

Please retain all parts of the original packaging in case it should be necessary to return items at any time. Only the original packaging should be used for return consignments.

Before despatch, disconnect all attached cables and loose/movable parts. Apply any intended transport security devices. Secure all parts, e.g. glass windshield, measuring plate, power unit etc., to prevent slipping and damage.

5. Unpacking, installation and commissioning

5.1 Place of installation, place of use

The instrument is constructed in such a way that reliable measuring results can be achieved under normal application conditions.

By selecting the correct application location for your instrument, you will be able to work quickly and precisely. Therefore please observe the following at the application location:

- Avoid extreme heat as well as temperature fluctuation caused by installing next to a radiator or in the direct sunlight;
- Protect the instrument against direct draughts due to open windows and doors;
- Avoid jarring during measuring;
- Protect the instrument against high humidity, vapours and dust;
- Do not expose the device to extreme dampness for longer periods of time. Inadmissible bedewing (condensation of air moisture on the device) can occur if a cold device is taken into a significantly warmer environment. In this case, please acclimatise the device for approx. 2 hours at room temperature after it has been disconnected from the batteries.

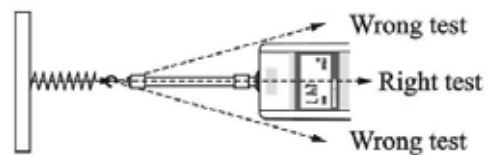

- Avoid static charging of the material to be measured, measuring container and windshield. Major display deviations (incorrect measuring results) are possible if electromagnetic fields occur as well as due to static charging and instable power supply. It is then necessary to change the location.

5.2 Unpacking

Carefully remove the instrument from its packaging, remove the plastic wrapping and position the instrument in its intended working location.

3. Working Conditions

10°C to 30°C / 15% up to 80% humidity

4. Power Supply

6 x 1.5 V AA, UM-3 Batteries

If batteries are low, display shows „Lo“

Instruction Manual

FT 1K

5. Zeroing & Measure



Zeroing of display

The tension and compression measuring function is executed automatically. Compression measuring shows „ – „ in front of measured result.

6. Normal Measurement

Slide Power Switch onto „I“

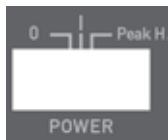

Choose unit and slide switch onto wanted unit

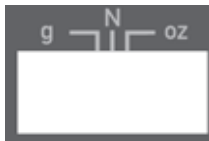

Put chosen attachment on

Zero adjusting by pushing Zero Button before all measurements

Activate display reverse if needed



Changes from FAST to SLOW:

- FAST: about 0,2 Sek.
- SLOW: about 0,6 Sek.

In case of overload display is showing „-----“

7. Peak-Hold Measurement

Power-Switch onto „Peak-H.“

Same as „Normale Measurement“

8. Backlight



Keep pressing for about 2 seconds

Turning off automatically after approx. 15 Sek.

9. RS 232 PC Serial Interface

The instrument features an RS232 output via 3.5 mm terminal. The connector output is a 16 digit data stream which can be utilized to the user's specific application. An RS232 lead with the following connection will be required to link the instrument with the PC serial input.

Meter
(3.5 mm jack plug)

PC
(9W 'D' Connector)

Center Pin.....Pin 2

Ground/shield.....Pin 5

16-digit-Signal:

D15 D14 D13 D12 D11 D10 D9 D8 D7 D6 D5 D4 D3 D2 D1 D0

Each digit indicate the following status :

D0	End Word
D1 & D8	Display reading, D1 = LSD, D8 = MSD <i>For example :</i> <i>If the display reading is 1234, then D8 to D1 is : 1234</i>
D9	Decimal Point(DP), position from right to the left 0 = No DP, 1 = 1 DP, 2 = 2 DP, 3 = 3 DP
D10	Polarity 0 = Positive 1 = Negative
D11 & D12	Anunuciator for Display g = 57 Newton = 59 oz = 58 Kg = 55 LB = 56
D13	1
D14	4
D15	Start Word

RS232 setting

Baud rate	9600
Parity	No parity
Data bit no.	8 Data bits
Stop bit	1 Stop bit