



KERN & Sohn GmbH

Ziegelei 1
D-72336 Balingen
E-Mail: info@kern-sohn.com

Tel: +49-[0]7433- 9933-0
Fax: +49-[0]7433-9933-149
Internet: www.kern-sohn.com

Operating instruction Precision balance

KERN EW

Version 2.1
07/2007
GB



EW-BA-e-0721



KERN EW

Version 2.1 07/2007

Operating instruction Precision balance

Contents

1	TECHNICAL DATA	3
2	UNPACKING AND STANDARD ACCESSORIES.....	5
3	SETTING UP THE BALANCE	5
4	EXTERNAL VIEW	6
5	INSTALLATION.....	7
6	POWER SUPPLY	7
7	DECLARATION OF CONFORMITY	8
8	ADJUSTING (CAL)	9
8.1	ADJUSTING FOR VERIFICATION.....	9
8.2	ADJUSTING (CAL)	10
9	OPERATING THE BALANCE.....	11
9.1	WARM-UP TIME	11
9.2	POWER DISPLAY	11
9.3	BALANCE ZERO DISPLAY	12
9.4	TARE WEIGHING (TARING).....	12
10	GENERAL PROGRAM SETTINGS	13
11	IMPORTANT INFORMATION	14
12	TROUBLE SHOOTING	15

1 Technical data

KERN	EW 150-3M	EW 600-2M	EW 1500-2M
Readout (d)	0,001 g	0,01 g	0,01 g
Verification value (e)	0,01 g	0,1 g	0,1 g
Weighing range (Max)	150 g	600 g	1.500 g
Min. load (Min)	0,02 g	0,5 g	0,5 g
Taring range	150 g	600 g	1.500 g
Reproducibility	0,002 g	0,01 g	0,01 g
Linearity	± 0,003 g	± 0,02 g	± 0,02 g
Recommended adjusting weight, not included (class)	1 x 100g + 1 x 20g (F1)	500 g (F2)	1 x 1 kg + 1 x 200 g (F1)
Stabilisation time	2 sec.		
Weighing plate, stainless steel	Ø 110 mm	Ø 140 mm	Ø 140 mm
Balance dimensions	180 x 230 x 85 mm		
Mains adapter	230 V, 50/60 Hz, balance 9 V DC, 400 mA		
Net weight (kg)	2,0		
Air humidity	max. 80 % relative (non-condensing)		
Ambient temperature	0° C to 40° C		
Authorised surroundings conditions for verifiable applications	10° C to 30° C		
Units	g, ct		
Vibration filter	yes		
Interface	RS 232 C interface (as option)		
Accu	as option		

KERN	EW 3000-2M	EW 6000-1M
Readout (d)	0,01 g	0,1 g
Verification value (e)	0,1 g	1 g
Weighing range (Max)	3.000 g	6.000 g
Min. load (Min)	0,5 g	5 g
Taring range	3.000 g	6.000 g
Reproducibility	0,01 g	0,1 g
Linearity	± 0,02 g	± 0,2 g
Recommended adjusting weight, not included (class)	1 x 2 kg +1 x 1kg (E2)	5 kg (F2)
Stabilisation time	2 sec.	
Weighing plate, stainless steel	Ø 140 mm	172 x 142 mm
Balance dimensions	180 x 230 x 85 mm	
Mains adapter	230 V, 50/60 Hz, balance 9 V DC, 400 mA	
Net weight (kg)	2,0	
Air humidity	max. 80 % relative (non-condensing)	
Ambient temperature	0° C to 40° C	
Authorised surroundings conditions for verifiable applications	10° C to 30 ° C	
Units	g, ct	
Vibration filter	yes	
Interface	RS 232 C interface (as option)	
Accu	as option	

2 Unpacking and standard accessories

Take the balance carefully out of the packing and store the plastic wrap for a possible future transport.

The standard accessories consist of:

- Balance
- Weighing pan
- Weighing pan support
- External mains adapter
- Operating instructions

3 Setting up the balance

- Place the pan base packed with the weighing pan on the balance. Fix it on the shaft by driving the knurled nut in the centre. Place the weighing pan properly on the pan base.
- Place the balance on a firm surface. See also chapter 11.
- Drive the adjusting legs to centre the bubble in the circle of the level (front left in the housing).

4 External view

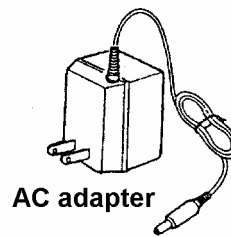
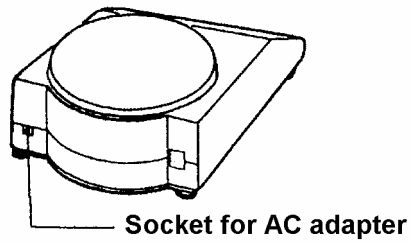
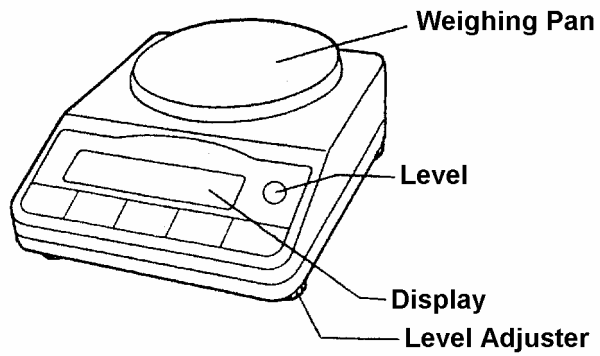

Key functions

ON/OFF	ON/OFF key for lighting display
Print	Print key or data transmission key
F	Function key, to call various functions
TARE	Zeroing / Taring key – parameter selection key

Display panel

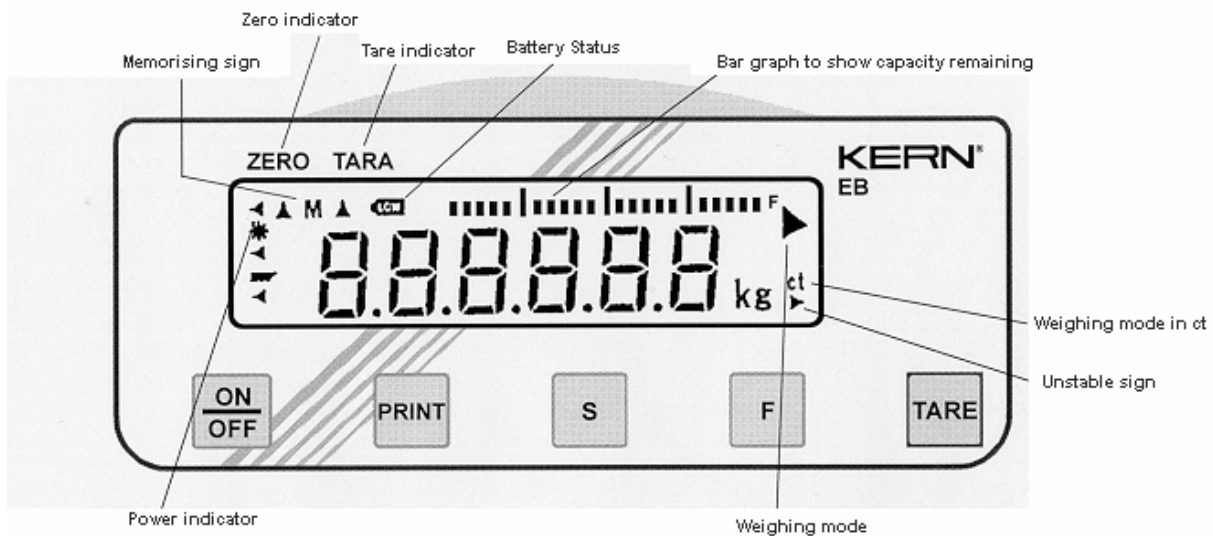

5 Installation

Please note that your KERN balance is a precision weighing instrument. Even if the instrument is made for robust and continuous use, please handle it carefully and do avoid unnecessary use.

The balance requires a warm-up time. The optimum weighing results are achieved when starting to use the balance only 5 minutes after turning it on.

6 Power supply

Plug balance into a socket 230 V / 50 Hz. Do not connect it when there should be another mains voltage.

Socket must be grounded as per VDE prescription. Inspection by authorised special electrical shop only.

Plug the adapter cable on the back of the balance.

Only then:

Plug the given mains adapter (230 V AC / 9 V DC / 400 mA) in the socket.

The balance is now in the Standby mode, see "Power Display **"

Press now the **ON/OFF** key

The balance performs now a self-check.

After approx. 5 - 8 seconds the balance is ready to operate.

7 Declaration of conformity



Declaration of conformity

The electronic precision balances

Type:	KERN EW 150-3M KERN EW 600-2M KERN EW 1500-2M KERN EW 3000-2M KERN EW 6000-1M
EC type approval certificate number:	T5026
Issued by:	NMI

correspond to the following EC directives:

EC directive EC directive EMC (about the electromagnetic compatibility)	Version 90/384/EWG Version 89/336/EWG
---	--

Applied harmonised norms, in particular

EN 45501, EN 50081-1, EN 50082-1

This declaration is only valid with the certificate of conformity by a notified body.

This declaration ceases its validity at each changing of the above mentioned apparatus which is not in accordance with **KERN**.

Date: 20 January 2000

Signature:

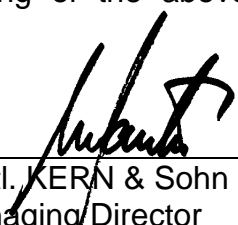
Gottl. KERN & Sohn GmbH
Managing Director

Gottl. KERN & Sohn GmbH, Ziegelei 1, D-72322 Balingen-Frommern, Tel. +49-07433/9933-0, Fax +49-07433/9933-149

8 Adjusting (CAL)

8.1 Adjusting for verification

General Information

Prior to the procedure of verification the balance has to be adjusted. See also section 8.2 Adjusting (CAL).

After the successful adjusting it is necessary to make the adjusting possibility impossible on KERN EW balances. The switch for this step is located on the inside of the balance (beneath the housing, above the display) (only with models KERN EW).

Blocking / Releasing of the adjusting function

Remark:

The adjusting is only possible when not being blocked by the adjusting switch.

Switch to the right	Adjusting function is blocked After successful adjusting the adjusting has to be blocked by this position of the switch. This setting has to be selected before starting to verify.
---------------------	---

Switch to the left	Adjusting function is released
--------------------	--------------------------------

The balance should be separated from the mains after each operation of the switches.

After the verification the cap has to be secured by a verification mark against access.

The balance is now prepared for the procedure of verification.

8.2 Adjusting (CAL)

Adjustment should be carried out with the recommended adjusting weight (see Chapter 1 „Technical Data“). The adjustment can also be carried out with different adjusting weights (see table), but not ideal from a metrological point of view.

Model	Alternative adjusting weight
EW 150-3M	50 g
EW 600-2M	200 g
EW 1500-2M	500g
EW 3000-2M	1.000 g
EW 6000-1M	2.000 g

Information concerning the adjusting weights is available at:

<http://www.kern-sohn.com>

Caution:

With verified balances the possibility of adjusting is made impossible. See section 8.1 Adjusting for verification.

Take account of stable ambient conditions.

A warm-up time of approx. 30 minutes is necessary.

Press **F** and hold pressed until appears, then release the key.

Press **Tare** and hold pressed. Immediately press **F** briefly and then also release **TARE**. Display .on briefly flashes.

Do not touch the weighing plate.

Shortly after this in the display appears

Place the adjusting weight(s) carefully in the centre of the weighing plate.

Display flashes and shows briefly the weighing value of the adjusting weight.

Take down the adjusting weight. The adjusting is completed.

In case of an adjusting error or to interrupt the procedure of adjusting, quit by pressing **S**.

Store the adjusting weight next to the balance for daily check on the accuracy of the balance.

Note:

Please handle the adjusting weight with care. Protect the adjusting weight from damage and dirt. Have it checked periodically. Store it next to the balance (to prevent from being mixed up).

9 Operating the balance

9.1 Warm-up time

Optimum weighing results are being achieved when starting to operate the balance only 5 minutes after turning the balance on.

9.2 Power display

ZERO TARE



If the symbol (*) is visible, the balance is provided with power via the mains adapter. By pressing the **ON/OFF** key the balance is in the weighing mode. Thus the power display in the balance display no longer is visible. It is recommended to turn the mains adapter off after having terminated to work with the balance.

Bar Graph display

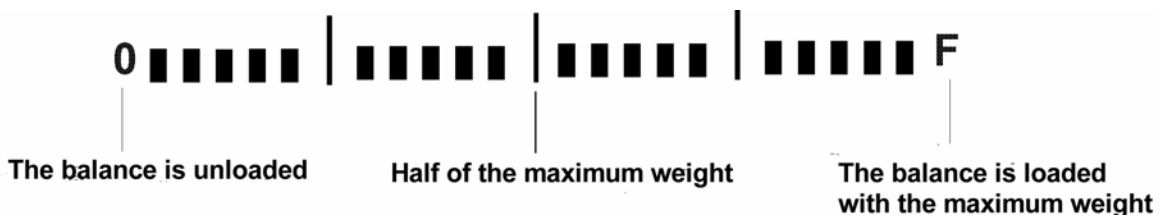

The weighing range of the balance is separated in 20 graphic cuboids. If the balance is not loaded, the zero (0) is displayed in the graphic display. If the balance is loaded up to the half of its weighing range, 10 graphic cuboids are displayed.

Note:

If the tare weighing is carried out, the graphic weighing display continues to show the quantity of cuboids of the tare weight.

9.3 Balance zero display

ZERO TARE

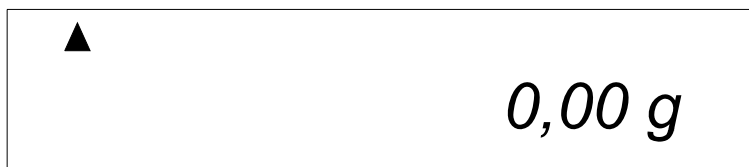

By pressing the **Tare** key the balance is set to zero. On the display appears 0,00 g. Additionally, the symbol for the balance zero display (ZERO) ▲ is displayed.

9.4 Tare weighing (taring)

- Place the tare cup on the weighing pan
- Press the tare key
- Balance display turns to 0,00 g
- The weight of the cup has been stored now internally.
- Put the load into the cup and read off the weighing value.

The tare process can be repeated as often as wanted, for example to weigh in several components as a mixture (weighing in).

The limit is reached when the whole weighing range is occupied.

After taking down the tare cup, the total weight appears on the display as a negative result.

Tare display

ZERO TARE

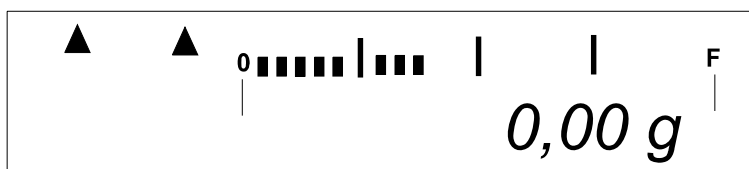

By pressing the **Tare** key the tare weighing is started.

On the display appears 0,00 g.

Additionally, the symbol for the tare display ▲ is displayed.

10 General program settings

The balance leaves the factory with the factory settings being set. This is the standard configuration of the balance. It is marked by a *.

It can be altered as follows:

Press the **F** key for about 4 seconds until **Func** appears on the display.

While releasing the key, **1. B.0. 0** appears on the display.

By pressing the **F** key several times, the single functions are accessed.

By pressing the **Tare** key several times, the individual setting within the single functions can be altered.

To accept and quit the program mode, press the **S** key.

The following changes are possible:

F	Tare
----------	-------------

<i>Graphic weighing display</i>	1. <i>b0G</i>	0	<i>Balance display is turned off.</i>
		1*	<i>Balance display is turned on.</i>
<i>Auto Zero</i>	3. <i>A.0</i>	0	<i>deactivated</i>
		1*	<i>activated</i>
<i>Automatic shut-down (Accu only)</i>	4. <i>A.P.</i>	0	<i>deactivated</i>
		1*	<i>Balance is shut down after 3 minutes when not in use.</i>
<i>Vibration filters</i>	5. <i>r.E.</i>	1	<i>Sensitive and fast</i>
		2*	<i>Medium</i>
		3	<i>Insensitive, but slow</i>
<i>Data transmission (output format) only with built-in serial data interface (as option)</i>	6. <i>o.c.</i>	0	<i>No data transmission</i>
		1	<i>Continuous serial data transmission</i>
		2	<i>Continuous serial data transmission at stable balance display</i>
		3	<i>Data transmission after pressing of Print</i>
		4	<i>Automatic output at balance load, new output only after taking the weight down and applying a new load.</i>
		5	<i>One output at stable balance display</i>
		6	<i>One output at random stabilisation, not documented</i>
7*	<i>One output after pressing of Print at stable balance</i>		

<i>Baud rate</i>	<i>7. b.L.</i>	<i>1* 2 3</i>	<i>1200 Baud 2400 Baud 4800 Baud</i>
<i>Unit commutation</i>	<i>8. Set.</i>	<i>1* 2 3 4</i>	<i>g g/ct not documented not documented</i>
<i>Not documented</i>	<i>0. GLP</i>	<i>1</i>	<i>Always use this setting</i>
<i>Not documented</i>	<i>A. PrF.</i>	<i>3</i>	<i>Always use this setting</i>

11 Important information

These electronic balances are precision instruments. It is designed for use in a self-controlled electromagnetic environment. That means that in such an environment radio equipment, such as mobile phones, must not be used in direct vicinity. In case strong electromagnetic fields should arise, deviations of the indication are possible. Avoid disturbing environmental conditions such as currents and vibrations as well as a rapid change of the ambient temperature. If necessary readjust the balance after a change of temperature.

Avoid high humidity, vapours and dust as the balance is not hermetically closed. Do not let the balance come into direct contact with liquids as these could enter the measuring cell. Therefore only clean the balance with a dry or damp cloth. Do not use solvents as varnished or plastic parts could be damaged.

A warming up time of a few minutes after switching the balance on will stabilise the measuring values. Place the object carefully on the weighing pan. Avoid any constant load on the weighing pan even when out of use. Avoid shocks, thrusts and extreme impairments by all means. Remove spillages immediately.

When the programme cycle is disturbed switch the balance off and then on again. Start the weighing operation again.

Never use the balance in rooms where there is a danger of explosion. The serial version is not explosion-proof.

Opening of the balance causes invalidity of warranty.
Check the balance daily with the supplied check weight.

If necessary adjust the balance.

The warranty is nullified if the balance is opened.

12 Trouble shooting

No indication.

the cable is defective).

*The balance is not turned on.
The mains connection does not
function (the cable is not connected,*

The mains supply has broken down.

The weighing display changes constantly.

*Air movements
Vibrations of the table or the floor.
The pan is in contact with an alien
element.*

*The adjusting is no longer correct.
The temperature varies strongly.*

Error messages

o-Err

The weighing range is exceeded.

b-Err

environment. If necessary, choose another location.

electrostatic field. Check

u-Err

pan support. The weighing pan does not lie on the

1-Err

Wrong adjusting weight (too light).

2-Err

The adjusting weight is too incorrect.

3-Err

weight is on the balance. At the beginning of the adjusting, a

4-Err

Grave error.

CAL. OFF

Error message only with models having an internal adjusting weight. The adjusting switch (right) is not in the "WEIGH" position.

If other error messages occur, turn the balance off and on again. The weighing result is obviously wrong.

If the error message still appears, please contact KERN.